

OVATION SERIES

Woodstoves and Fireplace Insert

OWNER'S MANUAL & INSTALLATION INSTRUCTIONS

*Read this manual and all safety notes
Keep for future reference*



Freestanding models: OV-1700, OV-2100, OV-2600, and OV-3000

Fireplace insert model: OV26-BF-I

All Ovation Wood Burning Stoves are EPA certified

American Energy Systems
150 Michigan Street SE
Hutchinson, MN 55350
320-587-6565
www.magnumheat.com

Copyright © 2008 by American Energy Systems

SAFETY NOTES

Warning: THE AUTHORITY HAVING JURISDICTION (such as municipal building department, fire department, fire prevention bureau, etc) SHOULD BE CONSULTED BEFORE INSTALLATION TO DETERMINE THE NEED TO OBTAIN A PERMIT.

Warning: Hot operation! Keep children, clothing, and furniture away from this product. Contact with skin may cause burns. Never leave children unattended when there is a fire burning in the wood-burning appliance.

Warning: Do not use chemicals, fluids, such as gasoline, kerosene, charcoal lighter fluid or other similar liquids to start or rekindle a fire. Keep combustible materials at least 48 inches clear of the wood-burning appliance at all times.

Warning: When cleaning the wood-burning appliance, all ashes should be placed in an approved metal container with a tight fitting lid. The closed ash container should be placed on a non-combustible floor or on the ground outside the house until the ash has had time to cool properly before disposal.

Warning: Do not burn garbage or other foreign matter in any wood-burning appliance.

Warning: Do not use products not specifically approved for use with this wood-burning appliance. Any such use violates the warranty in its entirety. Contact your local authorized Country Flame Dealer or Country Flame directly for any necessary clarification.

Warning: Country Flame does not recommend the use of solid fuel fire log products.

Warning: The use of some fuels (e.g. charcoal) can generate carbon monoxide and create hazards associated from carbon monoxides. Ensure the hazards of any solid fuel being used in the Ovation stoves are understood before burning occurs.

Warning: Country Flame strongly recommends the use of smoke and carbon monoxide detectors in your home. At a minimum, these devices should be checked on a semi-annual basis.

Warning: **CAUTION: DO NOT OVER FIRE THE STOVE.**
Over firing is created by burning large amounts of small wood pieces such as pallets, construction lumber, or combustible scraps for extended periods of time or over firing is created by burning the stove with the ash pan open. The stove should never be operated with the ash pan open. Either of these types of operation will create intense heat inside the appliance. With such over firing, extreme temperatures can occur on the outer surface of the stove and endanger occupants or combustible materials in the area of the appliance.

Warning: DO NOT CONNECT TO A CHIMNEY FLUE SERVING ANOTHER APPLIANCE.
This wood-burning appliance must be connected to (1) a listed type HT (2100°F) chimney per UL 103 or ULC S629, or (2) a code-approved masonry chimney. The chimney flue size should not be less than the appliance flue collar or more than three times greater than the cross-sectional area of the flue collar.

Warning: Do not use a grate or andirons or similar methods to elevate the fire.

Warning: Do not operate any wood-burning appliance without the ash pan installed and closed.

Warning: **Country Flame strongly recommends products** be installed and serviced by professionals who are certified by the Chimney Safety Institute of America or the National Fireplace Institute (U.S.) or Wood Energy Technical Training (Canada). Improper installation can produce property damage or personal injury.

Warning: Do not operate the appliance if the door glass is broken or a door gasket is missing or damaged. Use of a non-closed door or malfunctioning door or door subassembly may allow smoke to be drawn into the room. The door should remain closed during operation.

Warning: Fresh outside air must be supplied to this appliance from one of two sources: (a) Fresh air can either be admitted into the room (through an open window, door, etc.) If fresh outside air is provided in this manner a minimum of eight square inches of opening must be provided for use. (b) Or fresh outside air can be provided to the woodstove directly through a 4-inch diameter pipe connected to the stove's air inlet. It is dangerous to operate a stove with an outside combustion air inlet blocked or closed.

Warning: Burning of wet unseasoned wood can cause excessive creosote accumulation in the stove or chimney. If the creosote ever catches fire, it will create intense heat and is dangerous to both property and personnel. Chimneys should be annually inspected by a certified chimney sweep.

Warning: **Do not** install this stove in a garage or any other building where flammable materials or chemicals are stored.

Warning: **Do not connect** this stove to any air distribution duct or system.

Warning: **Read** this entire manual before installation and use of any Ovation stove. If a stove is not properly installed, a house fire may result. To reduce risk of fire, follow the installation instructions. Failure to follow instructions may result in property damage, bodily injury, or even death.

Warning: **All** attachments and connections of the chimney sections must be attached with a minimum of three sheet metal screws to the stove and to each adjoining section.

CERTIFICATION SAFETY LABEL (sample)



Listed Solid Fuel Burning Space Heater
Also Suitable For Use In Mobile Homes

Model: OV-1700 OV-2100 OV-2600
 OV-26BF-I Insert OV-3000

W/N 01863

Tested to: UL 1482, ULC S627, ULC S628
Report No.: 6385 (December, 1992)

WH- 4078

INSTALL AND USE ONLY IN ACCORDANCE WITH THE MANUFACTURER'S INSTALLATION AND OPERATING INSTRUCTIONS. CONTACT LOCAL BUILDING OR FIRE OFFICIALS ABOUT RESTRICTIONS AND INSTALLATION INSPECTION IN YOUR AREA. DO NOT CONNECT THIS UNIT TO A CHIMNEY FLUE SERVING ANOTHER APPLIANCE. USE 150 mm/6 in DIAMETER MINIMUM 24 GAUGE BLACK OR BLUED STEEL CONNECTOR, WITH LISTED TYPE HT FACTORY BUILT CHIMNEY OR MASONRY CHIMNEY. SEE LOCAL BUILDING CODE AND MANUFACTURER'S INSTRUCTIONS FOR PRECAUTIONS REQUIRED FOR PASSING A CHIMNEY THROUGH A COMBUSTIBLE WALL OR CEILING. MINIMUM CLEARANCE FROM HORIZONTAL CONNECTOR AND CEILING 455 mm/18 in.

MINIMUM CLEARANCES TO COMBUSTIBLE MATERIALS

		Conventional Models		Using Single Wall Connector		All Models, Mobile Home or Double Wall Connector
		Model OV-1700, OV 2100	Model OV-2600	Model OV-3000	Model OV-3000	
Sidewall to Unit	A	19 in/485 mm	20 in/510 mm	22 in/560 mm		14 in/355 mm
Backwall to Unit	B	10 in/255 mm	12 in/305 mm	12 in/305 mm		5 in/125 mm
Corner to Unit	C	6 in/150 mm	6 in/150 mm	8 in/205 mm		2 in/50 mm
Sidewall to Connector	D	28 in/710 mm	29 in/735 mm	31 in/790 mm		23 in/585 mm
Backwall to Connector	E	13 in/330 mm	16.5 in/420 mm	16.5 in/420 mm		9 in/230 mm
Corner to Connector	F	16 in/405 mm	16.5 in/420 mm	19 in/485 mm		11.5 in/290 mm

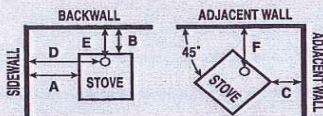

Components required for mobile home installation:

In Canada: Security DLS double wall connector, connected to listed chimney system conforming to the ULC S628 standard.

In U.S.A.: Use UL approved double wall connector, connected to UL approved HT chimney system.

Mobile home installation kit required for all installations.

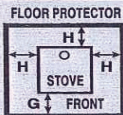

FLOOR PROTECTION

Combustible floor must be protected by a non-combustible material, extending (G) 18 in/455 mm to the front, and (H) 8 in/205 mm to the sides as indicated. Also under the chimney connector and 2 in/50 mm beyond each side.

ALCOVE INSTALLATION

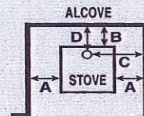

All models may be installed in a combustible alcove. Use only listed Security DLS or Duravent Plus double wall connector or equivalent.

Sidewall to Unit	A	14 in/355 mm
Backwall to Unit	B	6 in/150 mm
Sidewall to Connector	C	23 in/585 mm
Backwall to Connector	D	9 in/230 mm
Minimum Alcove Height		7 ft/2.13 m
Maximum Alcove Depth		4 ft/1.23 m

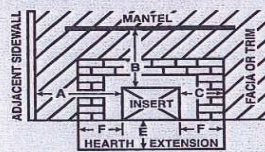

MODEL OV-26-BF-I INSERT

Adjacent Sidewall	A	17 in/430 mm
Mantel	B	28 in/710 mm
Side Facing	C	1 in/25 mm

Combustible floor must be protected by a non-combustible material extending (E) 18 in/455 mm to the front of unit, and (F) 8 in/205 mm to sides.

Combustible materials must not protrude more than 1" to the side of the insert, or between the mantel and the top of the insert.

OPERATE ONLY WITH FEED DOOR CLOSED. OPEN FEED DOOR TO FEED FIRE ONLY. FOR USE WITH SOLID WOOD FUELS ONLY. DO NOT USE GRATE OR ELEVATE FIRE. BUILD WOOD FIRE DIRECTLY ON HEARTH. DO NOT OVERFIRE. IF HEATER OR CHIMNEY CONNECTOR GLOWS, YOU ARE OVERFIRING. INSPECT AND CLEAN CHIMNEY FREQUENTLY. UNDER CERTAIN CONDITIONS OF USE, CREOSOTE BUILDUP MAY OCCUR RAPIDLY. KEEP FURNISHINGS AND OTHER COMBUSTIBLES WELL AWAY FROM HEATER. REPLACE GLASS ONLY WITH CERAMIC GLASS.

OPTIONAL COMPONENTS: FAN, ELECTRICAL RATING 115 V, 60 Hz, 1 AMP.

ROUTE CORD AWAY FROM HEATER.

MANUFACTURED BY: American Energy Systems, Inc.
150 Michigan Street SE, Hutchinson MN 55350



CAUTION

**HOT WHILE IN OPERATION. DO NOT TOUCH.
KEEP CHILDREN, CLOTHING AND FURNITURE
AWAY. CONTACT MAY CAUSE SKIN BURNS.
READ NAMEPLATE AND INSTRUCTIONS.**

U.S. ENVIRONMENTAL PROTECTION AGENCY
Certified to comply with July 1990 particulate emission standards.

Date of Manufacture

2009 2010 2011 Jan Feb Mar Apr May Jun Jul Aug Sep Oct Nov Dec

DO NOT REMOVE THIS LABEL

Made in U.S.A.

IGN

TABLE OF CONTENTS

SAFETY NOTES.....	3
CERTIFICATION OF SAFETY LABEL (SAMPLE).....	5
TABLE OF CONTENTS.....	6
EPA CERTIFIED.....	7
LISTING /TESTING AGENCY	7
OVATION LIMITED WARRANTY.....	9
OVATION OPERATING INSTRUCTIONS.....	10
FUEL.....	10
BLOWERS	10
FIRST FIRE	10
BUILDING A FIRE	10
COMBUSTION CONTROL	11
HIGH BURN MODE	12
MEDIUM BURN MODE	12
LOW BURN MODE	13
REFUELING FOR OPTIMUM PERFORMANCE.....	13
SMOKING – CAUSES.....	14
IMPORTANT NOTES	16
MAINTAINING AN OVATION STOVE	17
CREOSOTE.....	17
CHIMNEY MAINTENANCE.....	17
CHIMNEY FIRES	17
GOLD DOOR CARE.....	18
ASHES AND THE ASH PAN	18
FIREBRICK RETAINER	18
FIREBRICK REPLACEMENT.....	19
DOOR INSTALLATION	22
DOOR ADJUSTMENT	22
GLASS CLEANING.....	22
GLASS REPLACEMENT	23
GLASS-CERAMIC SPECIFICATIONS.....	23
GASKET REPLACEMENT	24
CLEARANCES	24
CHIMNEY.....	25
FACTORY-BUILT CHIMNEY	25
MASONRY BUILT CHIMNEY	26
ALCOVE INSTALLATION	27
FLOOR PROTECTION REQUIREMENTS	27
THIMBLE INSTALLATION.....	28
OUTSIDE AIR COMBUSTION	31
HEARTH PAD REQUIREMENTS.....	32
MOBILE HOME INSTALLATION.....	33
MOBILE HOME RULES	33

MOBILE HOME CLEARANCES.....	33
MOBILE HOME STOVE ATTACHMENT.....	34
MOBILE HOME FLOOR PROTECTION.....	35
MOBILE HOME CHIMNEY AND DUCTS.....	35
OVATION MODEL OV-26BF-I INSERT (BAY FLAME)	39
INSTALLATION, GENERAL RULES	39
INSTALLATION INTO FACTORY BUILT FIREPLACES.....	40
INSTALLATION INTO MASONRY FIREPLACES.....	41
BAY FLAME FIREBRICK INSTALLATION	44
OV26-BF-I INSERT CLEARANCES	45
OV26-BF-I ELECTRICAL.....	46
HOW IT WORKS.....	47
WOOD COMBUSTION BASICS	47
APPENDIX A: SPECIFICATIONS.....	50
APPENDIX B: OPERATING TIPS.....	51
APPENDIX C: REPLACEMENT PARTS	52

**READ, UNDERSTAND, AND CONFORM TO ALL INSTRUCTIONS PRIOR TO INSTALLATION AND OPERATION OF STOVES COVERED IN THIS MANUAL!
KEEP THIS MANUAL IN A SAFE PLACE FOR FUTURE REFERENCE**

EPA CERTIFIED



All Country Flame non-catalytic stoves have been certified by the United States Environmental Protection Agency.

LISTING/TESTING AGENCY

All Country Flame non-catalytic stoves have been tested to UL listing standards UL1482, ULC-S627, ULC-S628 for installation into residential dwellings, including standard construction units, mobile home, or modular home units. All non-catalytic stoves were tested to UL standards by Intertek Testing Services, NA, Inc., 8431 Murphy Drive, Middleton, WI 53562.



We recommend that our products be installed and serviced by professionals who are certified in the U.S. by NFI (National Fireplace Institute) or in Canada by WETT (Wood Energy Technical Training).

www.nficertified.org



American Energy Systems, Inc
150 Michigan Street SE
Hutchinson, MN 55350

WARRANTY INFORMATION

Name _____

Address _____ City _____

State: _____ Zip _____ Phone Number _____

Authorized Dealer _____

Dealer Telephone #: _____

Date Purchased: _____

Model No# _____ **Serial No#** _____

Installed By: _____

Trained By: _____

NOTE: FILL OUT THE ABOVE WARRANTY INFORMATION AND KEEP THIS COPY FOR YOUR PERSONAL RECORDS. REGISTRATION OF THIS WARRANTY CONSTITUTES YOUR ACCEPTANCE OF ALL TERMS CONTAINED THEREIN.

AMERICAN ENERGY SYSTEMS INC. LIMITED PRODUCT WARRANTY

This warranty is in effect on all products sold after 01/01/2009 and supersedes any and all warranties currently in existence.

Please keep a copy of this warranty for your personal records or in the event of a claim

American Energy Systems Inc., hereinafter referred to as (AES), warrants to you, the original consumer purchaser, that this product is free from defects in material and workmanship for a period of five (5) years from the original purchase date minus any time past one (1) year from manufacturing date, and that the product's electrical parts and steel firepot, are free from defects in material and workmanship for a period of one (1) year from the original consumer purchase date minus any time past one (1) year from manufacturing date, and that the cast iron firepot models carry a lifetime warranty against defect in material or workmanship (excluding war page or deterioration), and that door glass carries a lifetime replacement warranty against heat breakage (does not cover accidental breakage) . There is expressly no warranty on installation of product, any venting, grates, gaskets, door latches, insulation, ceramic or brick boards/logs/backing, paint, plated surfaces/doors/trims, baffles, bushings, bearings, auger flightings, war page or discoloration of steel or plated parts or any other normal wearing part. In the event the product fails to conform to this warranty, AES, through the place where you purchased the product or if purchased on the AES E-Com store directly through AES, will provide the parts and components necessary to remedy such nonconformity. **AES will not be responsible for any labor, mileage or freight cost to the factory under this warranty.** This warranty is not transferable.

In order to obtain performance under this warranty, you must (1) have registered this warranty within 30 days of purchase by completing and returning the warranty registration card or filling in the on-line warranty registration form at www.magnumheat.com, and (2) promptly report the claimed nonconformity to your place of purchase, also providing your name, address, phone number, proof of purchase, date of purchase, the model and serial number of the stove, digital pictures of installation and venting inside and outside of the home, pictures of the claimed nonconformity part and the claimed nonconformity. **All claims must be submitted in writing to your place of purchase.**

AES shall have no warranty obligations if this product; (1) was not purchased from an authorized AES dealer; (2) was not installed by a AES dealer or other qualified installer; does not have outside combustion air hooked directly to the unit; (3) was not operated and maintained in strict accordance with the manufacturer's instructions, local or national codes or (4) was subject to abuse, misuse, negligence or accident. AES shall have no warranty obligation for damage caused by improper handling, freight damage (must be reported to freight provider), over-firing, unapproved fuel, variance in feed rates, variances in BTU output or the unauthorized disassembly or modification of the product. AES shall have no warranty obligation if this warranty is not timely registered, for claims which are not submitted through the selling AES dealer, or for claims submitted verbally or without the required information and documentation.

Before exercising this warranty, an AES representative (the place where the product was purchased or AES approved person) must inspect the part/unit to determine if the part/unit is defective. If a local AES representative is not available the original purchaser of the product must submit digital pictures of the part/unit, installation of the unit to AES at technical@magnumheat.com If the inspection reveals that the failure is due to defective material or workmanship and the part is covered by the conditions of this warranty, AES will, at its option, repair the defective part/unit. The sole duty of AES and liability under this warranty is limited to the repair of the covered defective part/unit. The purchaser shall assume all costs related to shipping the replacement parts or return of the unit to the factory for repairs. If it is determined that the defect was caused by AES, AES will cover the costs of shipping the repaired part/unit to an AES approved shipping point. AES will not cover additional freight or delivery services such as residence delivery charges, special handling, etc.

INSTALLATION, VENTING, REMOVAL OR REINSTALLATION COSTS ARE NOT COVERED BY THIS WARRANTY.

THE WARRANTY PRINTED ABOVE IS THE ONLY WARRANTY APPLICABLE TO THE PRODUCT. ALL OTHER WARRANTIES, EXPRESSED OR IMPLIED, INCLUDING, WITHOUT LIMITATION, THE IMPLIED WARRANTIES OF MERCHANTABILITY AND FITNESS FOR A PARTICULAR PURPOSE, ARE DISCLAIMED. IT IS UNDERSTOOD AND AGREED THAT AES'S LIABILITY UNDER THIS WARRANTY SHALL BE LIMITED TO THE PROVISION OF REPLACEMENT PARTS AND SHALL NOT INCLUDE LIABILITY FOR SPECIAL, INCIDENTAL OR CONSEQUENTIAL DAMAGES. ANY ACTION BROUGHT UNDER THIS WARRANTY MUST BE BROUGHT WITHIN ONE YEAR OF THE ACCRUAL OF THE CAUSE OF ACTION AND MAY ONLY BE BROUGHT IN THE CIRCUIT COURT OF MCCLLOUD COUNTY, MINNESOTA.

Some states do not allow limitations on how long an implied warranty lasts or the exclusion or limitation of incidental or consequential damage, so the above limitations may not apply to you. This warranty gives you specific legal rights, and you may also have other rights which vary from state to state.

ALL WARRANTY CLAIMS MUST BE SUBMITTED IN WRITING THROUGH THE PLACE WHERE THE PRODUCT WAS PURCHASED. In the event where the place of purchase has ceased business or if you feel that there is a legitimate reason that you cannot submit your claim to the place where the product was purchased you may make a written request to the factory by emailing your request along with all of the required information to technical@magnumheat.com.

NOTE: Verbal requests will not be recognized. If it is determined that warranty could have been performed by the place of purchase, the factory will deny the claim.

Included with the claim must be the following information: (if this information is not complete, the claim will be denied)

Name, address, telephone number, email address, of place of business where product was purchased & also purchaser contact info.

Date of purchase, model and serial number of product, digital pictures of product (front, sides, back, venting inside and outside)

(If there is ductwork, there must be digital pictures of entire ductwork installation, static pressures, air flow measurements, and contact information of licensed/factory certified contractor that installed unit)

Nature of defect, what has been serviced (service record), who installed product along with contact information.

OVATION OPERATING INSTRUCTIONS

FUEL

Your Ovation Stove should be fueled with seasoned cordwood. Hardwoods will provide more energy per pound of wood because of higher density than softwoods. If hardwoods are utilized to fuel your appliance, the results will be a longer burning fire that requires less frequent refueling. It is recommended that whether hardwood or softwood is used, the moisture content of the wood should not exceed 20%. If wood moisture content is extremely high, the wood will be difficult to burn resulting in lower burn efficiency, increased creosote, and increased annual maintenance requirements. Very dry firewood will burn well but will increase emissions output and burn at accelerated burn rates requiring more frequent refueling of the stove.

Do not burn scrap, garbage, treated wood or wood such as driftwood which has been exposed to salt or other chemicals that will corrode the firebox and chimney. Do not burn large amounts of paper, cardboard, tree trimmings, or building construction materials. The intense fires these stoves create may overheat the stove thus causing damage to the unit, a fire outside the firebox, or even a chimney fire.

BLOWERS

All freestanding Ovation models have been approved for operation with or without an optional fan (blower). The optional blower kit may be mounted on the back of the unit per instructions provided.

The Ovation OV26-BF-I insert comes equipped with two blowers that have been factory installed. On medium to high burns, using a blower fan will increase the heat transfer and provide more room heat. Properly route the power supply cord (usually along the floor behind the stove) so that it remains cool with no chance of melting against the stove.

FIRST FIRE

Before using your Ovation Stove for the first time, ensure that all packaging material has been removed. Remove all glue with mild soap and ensure the door window has been cleaned of all foreign material before starting the first fire. If a gold door has been purchased, ensure proper cleaning before the first fire. Permanent damage can occur to the gold finish if proper cleaning is not completed prior to the FIRST burning.

It is best to ensure that the first three fires are small and short in duration. Use small amounts of firewood to limit the fire to a hour burn. Repeat this process at least three times, letting the firebox cool between fires. The purpose of these small fires is to allow proper curing of the refractory bricks and the exterior paint. The first fires may produce slight smoking due to curing of the paint and steel. In addition, any dust that has accumulated on the stove will burn off during these first few fires. The owner should be prepared to open windows for ventilation during the first few fires. The owner should be alert to setting off a smoke alarm that is located in the same or adjacent rooms to the Ovation Stove.

BUILDING A FIRE

Check for proper draft. Preheat the flue if necessary in order to establish proper draft. Several crumpled balls of newspaper can be placed into the firebox to preheat the chimney. Once the chimney system is heated, additional small crumpled papers can be added with small dry pieces of kindling added on top of the paper. Crisscrossing this small kindling over the paper will create airspace between the kindling thus ensuring a quicker start to the fire. It is important that air can circulate around the kindling during the start up process. Open the Ovation Stove combustion air control fully (pull handle to its fully extended position) and ignite the newspaper with a match or

lighter. Hold the door slightly ajar until a good flame is established (2 or 3 minutes). Close the door to the stove once the newspaper is well ignited. As soon as the kindling fire is established, you can add cordwood. It is recommended that cordwood be placed inside the firebox from front to back (that is the fuel should have its longest dimension perpendicular to the door) and not crisscrossed or placed crossways in the firebox.

The Ovation Stove should be operated with the air control fully open until such time that the owner believes the fire is well established. In the event the air control is closed before the Ovation reaches efficient operating temperature the heating performance of the stove will be diminished. Experimentation will be required in order to familiarize you with establishing optimum burning and therefore maximum heating efficiency. Remember, the Ovation has over 100 pounds of firebrick that must be thoroughly heated in order for the stove to operate efficiently. Do not use grates, andirons, or other devices to elevate the firewood. Once the stove heats up, the operator can adjust the primary air control to the desired setting.

COMBUSTION CONTROL

Although not recommended, the Ovation system can be operated with a flue damper installed. This flue damper must then be used in conjunction with the Ovation combustion air control in order to control the burn rate of the appliance. As is standard practice with hi-tech high efficiency stoves, the Ovation combustion air control controls all air entering the firebox. This combustion air control allows the owner more precise control of the fire by accurately controlling the air available for combustion. The combustion air control is located below the ash lip at the center of the stove, as shown in FIGURE 1. This control is fully open when pulled out or away from the stove. The combustion air control is completely closed when the control lever is pushed all the way into the stove. To ensure no air leakage or air infiltration into your home when the Ovation Stove is not in use; the combustion air control lever should be kept in its closed position.

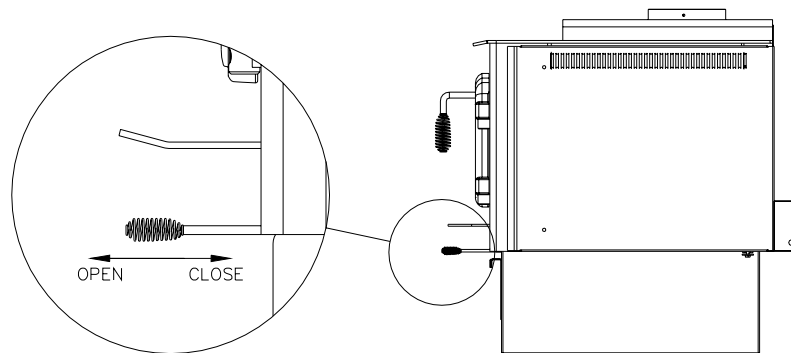

FIGURE 1: COMBUSTION AIR DAMPER CONTROL

This will minimize air leakage through the chimney. The combustion air control should be fully opened before opening the door to eliminate the possibility of a back draft into the room where your stove is located. Open the door slowly to avoid back drafting or back puffing. In addition, by fully opening the combustion air control, the stove will immediately start an accelerated burn; therefore, gloves (leather wood-burning gloves are recommended) should be worn when adding fuel or for any use when the door is open to the appliance. Wearing gloves will assist in avoiding burns due to the intense heat of the stove.

HIGH BURN MODE

The maximum heat output can be obtained from your Ovation Stove by operating the firebox with a full load of wood, the door closed, and the combustion air control fully open. This high burn mode ensures an extremely hot fire while generating the maximum heat output. The Ovation line of stoves can produce a maximum range of between 60,000 to 70,000 BTU of heat per hour, depending on the model being burned. Operating the Ovation in the high burn mode will necessitate the need for refilling the firebox with fuel more frequently. The amount of fuel needed and the time between refueling is dependent on many factors including moisture content of wood, type of wood, environmental factors, and chimney type and height. To obtain a longer burn time, the combustion air control can be partially or fully closed. By adjusting the combustion air control from its fully open position, the owner will obtain longer burn times by reducing the burn rates of the fuel. These reduced combustion modes are covered in the following paragraphs.

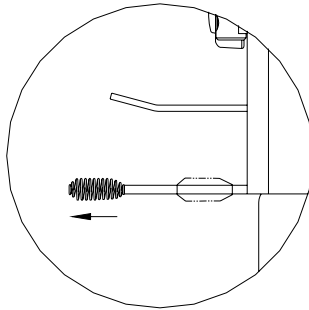

FIGURE 2: HIGH BURN AIR DAMPER SETTING

CAUTION must be used when operating the Ovation Stove with the combustion air control fully open. Only seasoned hardwood should be burnt in this manner. Burning softwoods, small dry pieces of construction scraps, trash or paper with the combustion air control wide open will cause a very high temperature fire to be created. This high temperature fire can permanently damage the Ovation firebox or create hazardous situations. Extreme care must be exercised when operating any stove in an accelerated combustion mode. In fact, Country Flame strongly recommends that the Ovation appliance **NOT be operated** in an accelerated combustion mode for more than one hour continuously. Failure to observe this recommendation may cause excessive heat buildup and damage the gold door plating or the cast door paint.

MEDIUM BURN MODE

Country Flame recommends that medium combustion mode operation be utilized for routine operation of the Ovation Stove. Operating the stove in the medium combustion mode will minimize the amount of creosote on the glass and in the chimney while providing extended burn times as compared to high burn mode. The combustion air damper should be set somewhere between the $\frac{1}{4}$ and $\frac{1}{2}$ closed position as shown in FIGURE 3 to obtain a medium combustion fire. The precise setting for your Ovation Stove combustion air control depends on many factors, including chimney length, wood moisture content, draft, and fuel selection. Do not be afraid to experiment to find the optimum position to satisfy your requirements for a warm and satisfying fire. As an example, a tall warm chimney will necessitate closing the combustion air damper more due to the natural draw created by the flue gases being drawn through the chimney. A stovepipe thermometer should be used for maximum stove performance and safety.

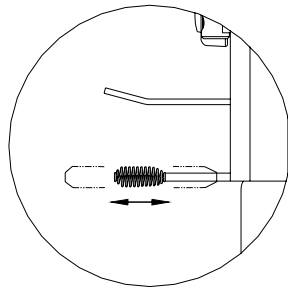

FIGURE 3: MEDIUM BURN AIR DAMPER SETTING

To establish proper medium combustion burn mode, close the combustion air damper completely and then set the combustion air damper somewhere between the $\frac{1}{4}$ to $\frac{1}{2}$ closed setting. The firebox should contain at least several medium size pieces of wood burning on a bed of hot coals. The Ovation Stove heat output will be between 30,000 and 50,000 BTU per hour in the medium combustion burn mode. In order to maintain a constant medium heat output, load more firewood about every four to five hours. Burn times and heat output will be significantly reduced if softwoods are used in place of seasoned hardwoods.

LOW BURN MODE

When the Ovation Stove air combustion control is fully closed, as shown in FIGURE 4, a low combustion fire will occur. Low combustion will not put the fire out but there will be a noticeable change in the flame pattern. The flames will be slow and intermittent and may appear dirty if the wood is too wet i.e., a moisture content of 20% or more.

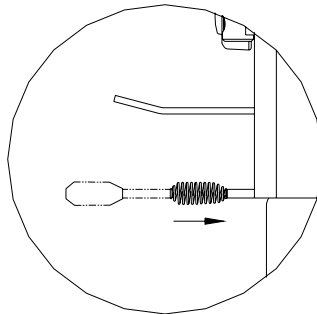

FIGURE 4: LOW BURN AIR DAMPER SETTING

During the low combustion burn mode, creosote may accumulate on the glass doors. Low combustion burning should only be used after the firebox has been allowed to reach a hot operating temperature i.e., the air combustion control has been fully open to produce a hot fire for about an hour. Low combustion can be used at night in order to reduce the heat output and to prolong the burn. The loading time will be between six to twelve hours. This however, may cause excessive creosote buildup.

REFUELING FOR OPTIMUM PERFORMANCE

The Ovation Stove performance will be greatly enhanced if the operator will fully open the combustion air control after refueling. If this process is followed, the firebox and chimney system will return to optimum operating temperature in the shortest period of time. Combustion efficiency is directly affected by firebox temperature. Following the above stated process will ensure maximum efficiency of your stove over the longest period of time. The upper part of the firebox temperature should exceed 1,200 degrees Fahrenheit or higher in order to achieve maximum

operating efficiency. To obtain this firebox temperature after reloading of wood, the Ovation should be operated with the combustion air control fully open for a minimum of 15 to 30 minutes. Again, the time will vary depending on the room heat, moisture content of the wood and the type of wood being burned. Once the Ovation has reached a proper operating temperature, the combustion air control can be gradually closed. A good indication that the proper temperature has been reached is when a flame can be seen at the top of the firebox. This upper fire indicates excellent combustion and will ensure cleaner glass, less creosoting, greater efficiency, and the greatest warmth and viewing pleasure for your family to enjoy.

SMOKING – CAUSES

Ensure the combustion air damper is fully open before the stove door is opened. Fully opening the damper will reduce the problematic issue of smoke escaping from the Ovation Stove when its door is opened. **CAUTION: ALWAYS** open the door very slowly. This will ensure that the stove is drafting through the fresh air intake and the chimney system rather than using your house as a source for air or the expulsion of air. Your stove has been designed and tested to provide smoke free operation. Occasionally, there may be a small amount of smoking due to the fact that the chimney system has not reached proper operating temperature. A warm chimney system ensures maximum draft efficiency for the firebox. If the stove continues to smoke, it is probably for one of the following reasons:

1. Doors Partly Open

Always operate the Ovation Stove with the door fully closed.

2. Negative Pressure

As the fire burns, the exhaust gases are drafted up and out of the chimney system. The Ovation Stove is “pulling” fresh air from somewhere to keep the fire burning properly. A stove will draw air to the firebox from inside the house if no other source of fresh air is available. Remember that a minimum of eight square inches of fresh air must be available if the four-inch outside air duct is not used with the Ovation. If your Ovation Stove has been properly installed, fresh combustion air will be supplied through some outside available air source. Check the Ovation Stove by temporarily opening a window near the stove. With the door closed and a fire operating, you should see no change in the fire when the window is temporarily closed. This check ensures your Ovation Stove has an adequate air supply

3. Fan Operation (i.e., bathroom, kitchen, attic, clothes dryer, etc.)

Exhaust fans draw air out of a home and may actually create negative pressure (absence of air or reduced air pressure inside a well sealed home.) When operating your Ovation hi-tech stove, ensure that all of your home’s exhaust fans are turned off or that a window is opened slightly to ensure these fans do not create a negative pressure inside your home. If these exhaust fans are operated, even with a window slightly open, they still may pull so much air from the house as to create a smoke condition inside the home.

4. Wet Wood

Wet or uncured firewood or wood with high sap content will smolder and smoke instead of burning as efficiently as seasoned woods. Improperly seasoned wood will increase annual maintenance and operating costs of your Ovation Stove. It is worth your time, money, and enjoyment to ensure that you have good seasoned wood to burn in your Ovation Stove.

5. Blocked Chimney

The chimney serves as an exit for all gases created during the burn process. Blockage (heavy soot, dirt, or debris) of either the chimney or the air intake port may make the Ovation Stove operate improperly or render it unusable. Always ensure, prior to the heating season, that a qualified chimney sweep or stove service technician has checked the stove, chimney, and any outside air intake system for proper operation.

6. Chimney To Short

The Ovation Stove minimum chimney height is 8 feet. The chimney must extend at least 3 feet (915 mm) above its point of contact with the roof and at least 2 feet (610 mm) higher than any roof or wall within 10 feet (3 cm) of it. If installed with offsets, the minimum chimney height is 12 feet. Additional chimney height will increase draft and therefore will decrease the tendency of the Ovation to smoke. FIGURE 5 shows a sloped roof chimney installation.

FIGURE 5: CHIMNEY INSTALLATION DIMENSIONS

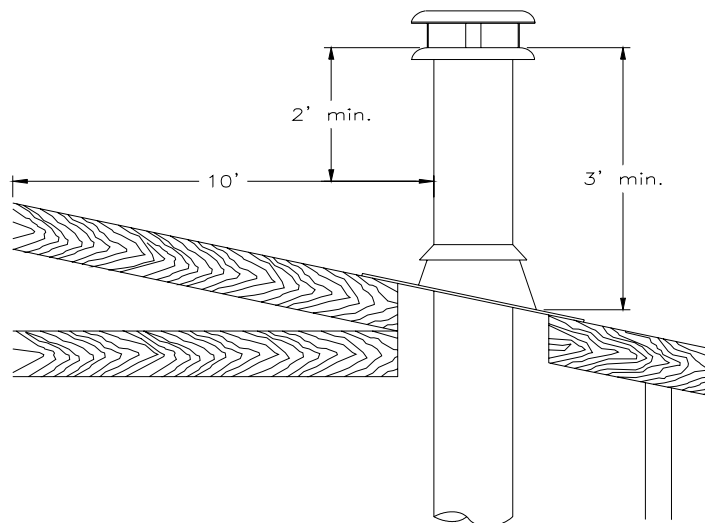

7. Poor Chimney Draft

Perform the following simple test of your chimney draft. With no fire in the Ovation firebox hold a lit match (smoke should be trailing from the match) inside the firebox towards the upper one third of the top of the firebox. If the draft is proper, you should see the match smoke exhausted up through the firebox. Chimneys installed against an outside wall without insulation may generate back draft problems, which will cause problems in starting your Ovation fire. This problem occurs because the chimney is cold and thus holds its temperature for some time despite a fire in the firebox. To minimize this problem open a nearby window. Now roll up a piece of paper and light it inside the firebox. Hold this lit paper towards the upper part of the firebox. It may be necessary to repeat this step several times in order to obtain proper operating temperature in the chimney so a good draft can be sustained. Be careful not to burn yourself with the paper. Once you see the smoke from the lit paper is drafting better you can build a better fire.

IMPORTANT NOTES

1. Never use gasoline, kerosene, charcoal lighter fluid, or other flammable liquids to start a fire.
2. Do not burn coal. The sulfur in coal will corrode the firebox.
3. Do not burn ocean driftwood or other waterlogged wood. The salt will corrode the firebox and chimney.
4. Do not operate the Ovation Stove with its door partially open, except for the first few minutes during startup.
5. Do not abuse your Ovation Stove by burning paper, cardboard, or construction material such as pressed wood, plywood, or lumber as part of a normal fire.
6. Do not allow wood to smolder or burn without flame, this will produce excessive creosote in the unit. The flame is an indication that the solid fuel is decomposing and burning off gases. Without a flame, these gases will add to the cooling effect, remain unburned, and add to annual maintenance costs.
7. Never operate your stove with the ash drawer open.

MAINTAINING AN OVATION STOVE

CREOSOTE

When wood is burned slowly, it produces tar and other organic vapors which combine with expelled moisture to form a black deposit called creosote. Creosote is unspent fuel. Creosote is an indication of improper operation of the stove, improper fuel or high moisture content, improper combustion airflow, or improper installation. Creosote will accumulate on the interior of all stove, connector pipe, and chimney linings. If left to build up, creosote can create a potential fire hazard within the stove and chimney system. When ignited, creosote burns extremely hot. If the creosote deposit within a chimney system is large, then the resultant chimney fire will damage the firebox, chimney, and potentially overheat a surrounding wood frame within the house causing a structural fire.

Creosote formation can be kept to a minimum by routinely building small hot fires rather than slow burning, smoldering fires, by proper refueling of a fire, by ensuring proper combustion air availability, and by monitoring the fire during the burn process. In addition, each year the homeowner should have the Ovation Stove and chimney inspected and cleaned as necessary to assist in preventing chimney fires.

CHIMNEY MAINTENANCE

Regular chimney inspection and maintenance combined with proper operation will help prevent chimney fires. The golden rule of operating a stove is to **KEEP THE CHIMNEY CLEAN**. Do not allow more than one sixteenth of an inch of creosote buildup in the Ovation Stove or chimney system. The amount of creosote created by operating the Ovation Stove will depend on variables such as the frequency of use and the type of fire that is routinely burnt. We recommend:

1. Inspect the chimney system weekly or before each use. From this the operator will gain knowledge of how often it will be necessary to clean or have the chimney cleaned.
2. Hire a qualified chimney sweep to clean the Ovation Stove and chimney system at least once a year.
3. Do not use chemical cleaners to keep your chimney clean. If necessary, the rain cap at the top of the chimney system can be removed to inspect or clean the chimney system. There are a number of different methods used to attach a rain cap to a chimney; therefore, it is recommended you consult the manufacturer of such systems on how to best remove the rain cap. Once the rain cap is removed, increased access allows for better inspection or cleaning of the chimney system.

CHIMNEY FIRES

Regular Ovation chimney maintenance and inspection will minimize the potential of a chimney fire. If the Ovation Stove owner ever encounters a chimney fire, follow these steps:

1. Alert any occupants in the house of the fire danger and ensure that everyone exits the building in a quick and orderly fashion.
2. Keep the stove door fully closed and immediately close the combustion air control.
3. Call the local fire department. It is better to have the fire department arrive before they are needed than after the house is already in flames.

4. Always use a dry chemical fire extinguisher, baking soda, or sand to control the fire. Do not use water as it may cause a dangerous steam explosion.
5. Inspect outside the house to ensure that sparks and hot embers coming out of the chimney are not igniting the roof or any adjacent building or property.
6. If a chimney fire has ever occurred, **DO NOT USE THE OVATION STOVE** again until both a qualified chimney sweep and a local fire department inspector reviews the system and provides written approval that the stove and chimney may be used.

GOLD DOOR CARE

The Ovation gold door should be wiped down regularly to ensure that the luster and beauty of the door lasts the life of the stove. Always use an approved glass cleaner (i.e. Windex, Glass Plus) and a lint free soft cloth to polish the doorframe. **DO NOT** use any abrasives, like steel wool, brass polish, cleaners, like Comet, or other household cleaners. If improper cleaners are used, the Ovation door will be permanently scratched and the finish ruined. A damaged door can be returned to Country Flame for refinishing. Country Flame can accomplish door repair for the Ovation Stove owner but it is expensive. With proper care in cleaning the Ovation gold door and other polished surfaces, expensive repair can be avoided and a lifetime of enjoyment will be yours.

Black doors require no specific care.

ASHES AND THE ASH PAN

The Ovation Stove has an ash pan located in the bottom of the firebox. Access to this ash pan is obtained below the ash lip at the bottom of the stove. Always remove ashes after they have been allowed to cool properly. Hot ash is dangerous to both surrounding areas and occupants and can cause fires or severe burns. Wait until the fire has been out for a minimum of 24 hours. Then open the bottom ash pan and remove it. Proper gloves should be worn anytime the ash pan is removed. Dump the ash in a proper ash container and remove to a safe outdoors area. Remember that although the ash may look and feel cool to the touch, a smoldering ember can start a fire. **CAUTION:** Care should be used to store any ash in a proper container with an approved airtight lid. If ash is taken outside, water should be poured over the ash to ensure no fire flare up can occur.

FIREBRICK RETAINER

Both back wall and side wall retainers are provided with the Ovation product to ensure firebrick are held in place during operational use. Ensure that these items are installed properly after setting all brick in place inside the Ovation product.

SIDE BRICK RETAINER (both sides)

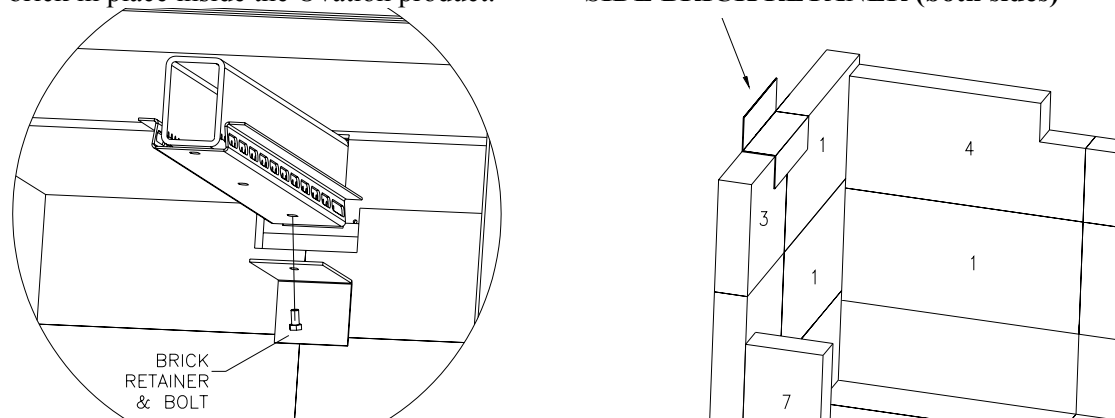

FIGURE 6a: INSTALLATION OF FIREBRICK RETAINERS

FIREBRICK REPLACEMENT

The intense repetitive heat inside the Ovation firebox will normally cause hairline cracks in the firebrick. Proper curing as described in “first fires” will minimize these cracks and extend the life of the Ovation firebrick. Small cracks will not normally diminish the effectiveness of the firebrick; however, if large cracks develop in the firebrick, replace them. To replace the Ovation firebrick refer to the following stove specific firebrick replacement charts:

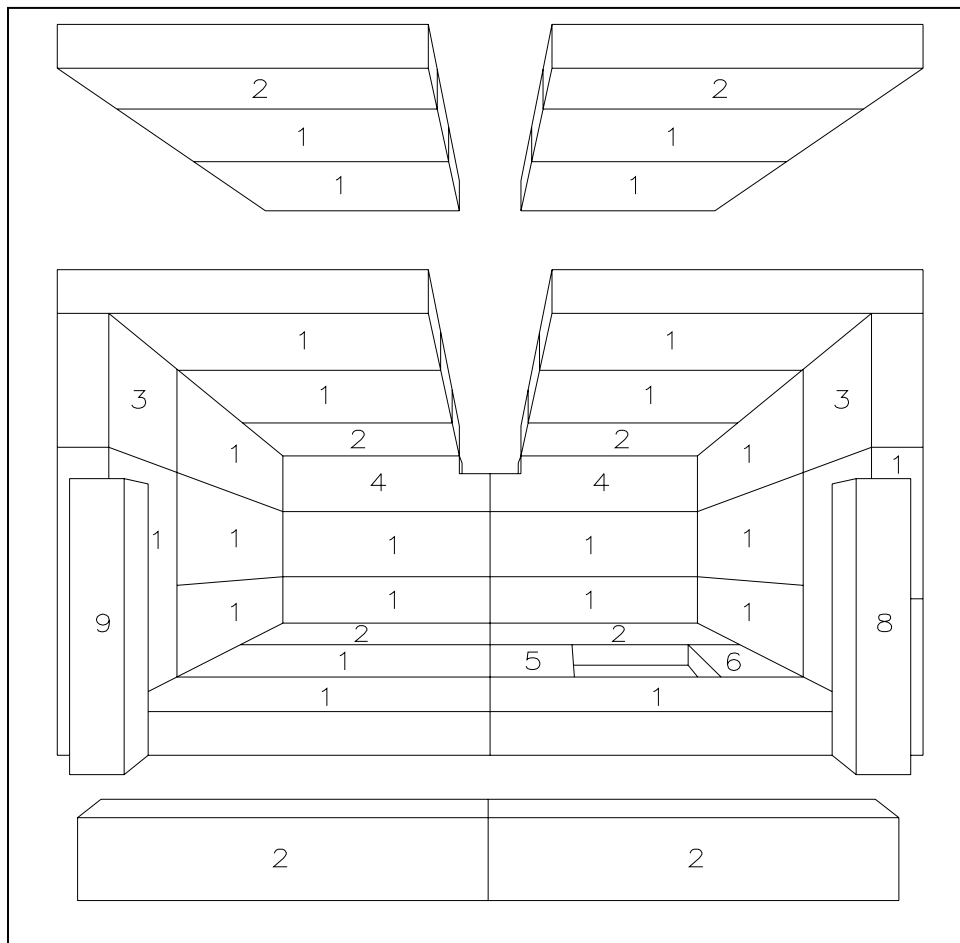

FIGURE 6b: OVATION MODEL 1700 and 2100 FIREBRICK SYSTEM

	BRICK PART NO.	SIZE OF BRICK
BACK		
(4) - #1	PP-868 - #1	- 1 ¼ X 4 ½ X 9 (FULL SIZE)
(2) - #4	PP-868 - #2	- 1 ¼ X 3 X 9
	PP-868 - #3	- 1 ¼ X 4 ½ X 4 ½
SIDES	PP-868 - #4	- 1 ¼ X 4 ½ X 9 (NOTCHED)
(8) - #1	PP-868 - #5	- 1 ¼ X 2 ½ X 4 ½ (not 1700, use #1)
(2) - #3	PP-868 - #6	- 1 ¼ X 1 ½ X 4 ½ (not 1700)
	PP-868 - #7	- (NOT USED)
TOP	PP-868 - #8	- 1 ¼ X 1 1/8 X 9
(8) - #1	PP-868 - #9	- 1 ¼ X 1 ½ X 9
(4) - #2		
FLOOR		
(3) - #1		
(2) - #2		
(1) - #5		
(1) - #6		
FRONT		
(2) - #2		
(1) - #9		
(1) - #8		

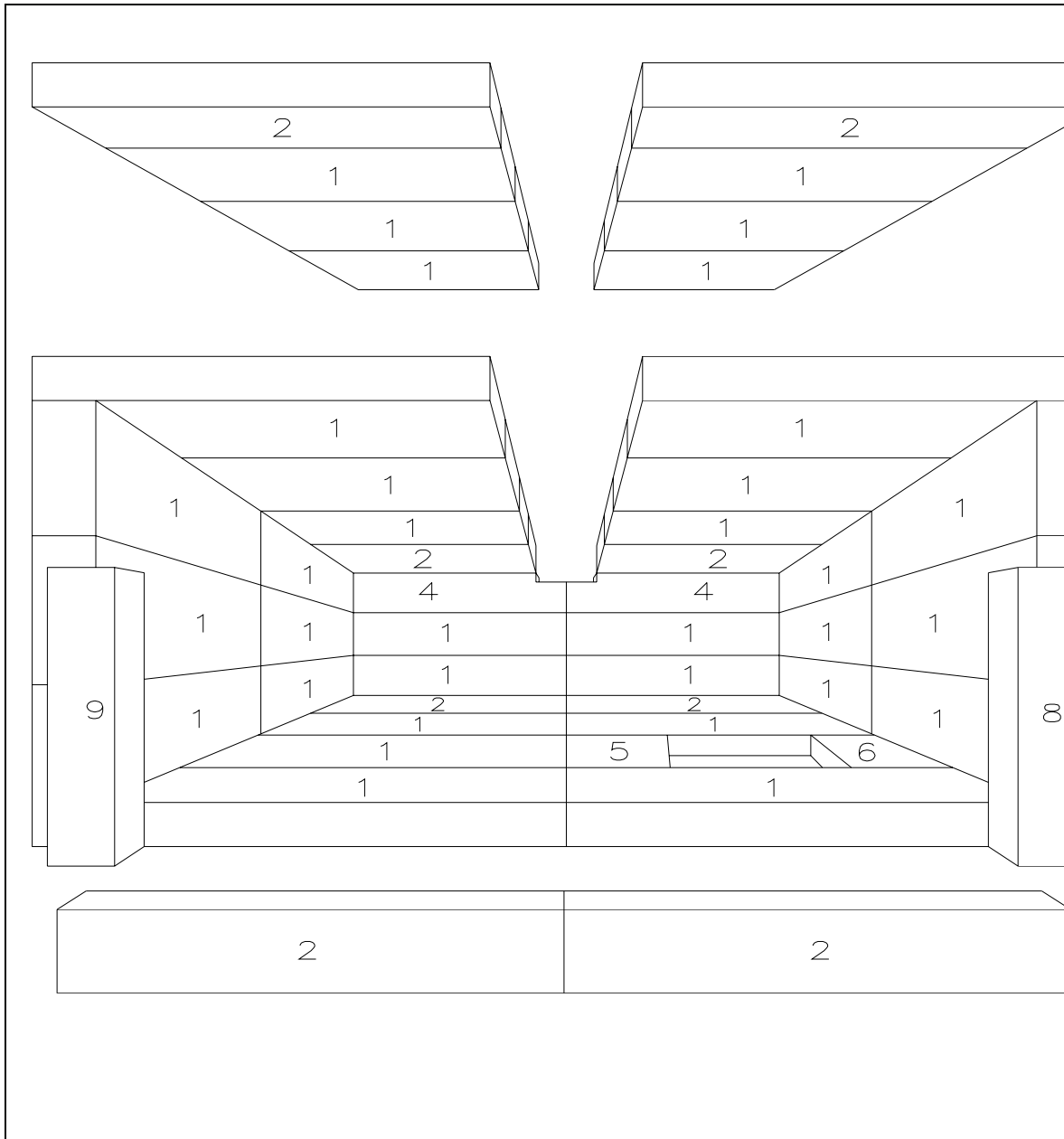

FIGURE 6c: OVATION MODEL 2600 FIREBRICK SYSTEM

		BRICK PART NO.	SIZE OF BRICK
BACK	FLOOR		
(4) - #1	(5) - #1	PP-868 - #1	- 1 1/4 X 4 1/2 X 9 (FULL SIZE)
(2) - #12	(2) - #2A	PP-868 - #2	- 1 1/4 X 3 X 9
	(1) - #5	PP-868 - #2A	- 1 1/4 x 3 1/2 x 9
SIDES	(1) - #6	PP-868-#12	- 1 1/4" x 3 1/2" x 9"
(8) - #1	FRONT	PP-868 - #5	- 1 1/4 X 2 1/2 X 4 1/2
(4) - #2A	(2) - #2	PP-868 - #6	- 1 1/4 X 1 1/2 X 4 1/2
	(1) - #9	PP-868 - #7	- (NOT USED)
TOP	(1) - #8	PP-868 - #8	- 1 1/4 X 1 1/8 X 9
(12) - #1		PP-868 - #9	- 1 1/4 X 1 1/2 X 9
(4) - #2a			

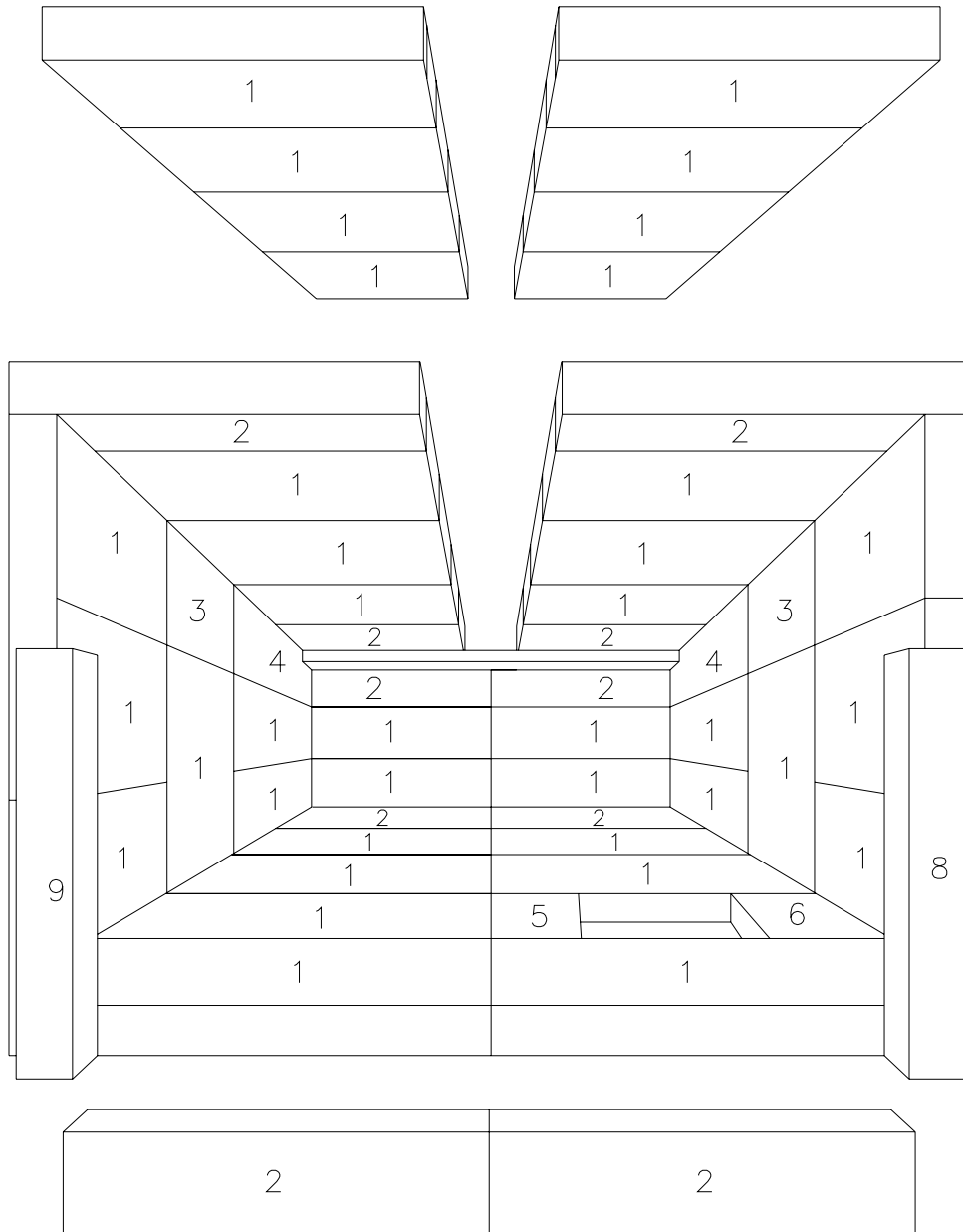

FIGURE 6d: OVATION MODEL 3000 FIREBRICK SYSTEMS

	FLOOR	BRICK PART NO.	SIZE OF BRICK
BACK	(7) - #1	PP-868 - #1	1 1/4 X 4 1/2 X 9 (FULL SIZE)
(4) - #1	(2) - #2	PP-868 - #2	1 1/4 X 3 X 9
(2) - #2	(1) - #5	PP-868 - #3	1 1/4 X 4 1/2 X 4 1/2
SIDES	(1) - #6	PP-868 - #4	1 1/4 X 4 1/2 X 9 (NOTCHED)
(12) - #1	FRONT	PP-868 - #5	1 1/4 X 2 1/2 X 4 1/2
(2) - #3	(2) - #2	PP-868 - #6	1 1/4 X 1 1/2 X 4 1/2
(2) - #4	(1) - #9	PP-868 - #7	(NOT USED)
TOP	(1) - #8	PP-868 - #8	1 1/4 X 1 1/8 X 9
(14) - #1		PP-868 - #9	1 1/4 X 1 1/2 X 9
(4) - #2			

DOOR INSTALLATION

The Ovation door has been mounted and checked for proper fit at the factory. If the door is removed for any reason, care must be taken in reinstalling the door to ensure proper alignment and fit. Setting the door is quite simple. Ensure the door is in the fully open position. Once done, align the female portion of the door hinge with the male portion of the stove hinge. Gently lower the door hinges over the stove hinge. Once the door hinges have been set, the door can be closed to check for proper fit. The Ovation door installation should now be complete. To remove the door, simply lift up on the door from the stove hinges. Store the door in a secure place. If the door is left sitting, ensure that the door cannot fall and injure someone or damage the door or glass. The Ovation door has been adjusted at the factory. If the door fit is not satisfactory, the owner can adjust the door using the hinge screws, refer to FIGURE 7.

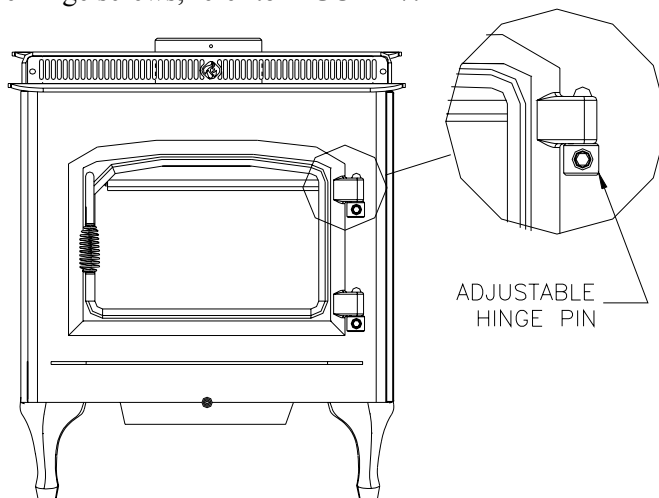

FIGURE 7: DOOR ALIGNMENT POINTS

DOOR ADJUSTMENT

The Ovation door may require fine adjustment due to variations in the door, the gasket material, or due to hinges being slightly ajar. After extended use, the door may also require some minor adjustments to maintain a center-aligned appearance. The Ovation door needs to remain airtight to ensure proper firebox operation. The Ovation door can be adjusted up or down and left or right with the adjustable hinge pins as shown in FIGURE 7.

The door gasket air tightness can also be adjusted to ensure an airtight fit. To adjust the gasket tightness, simply rotate the door latch clockwise (tighten) or counterclockwise (loosen) one complete revolution or as necessary to adjust the gasket seal. A good test to evaluate proper door gasket seal is to lay a dollar bill against the stove frame and then close and latch the door. If gently tugging on the dollar bill does not dislodge it from the door, the seal is appropriate. In the event that a proper door gasket seal cannot be obtained, it may be time to replace the door gasket.

GLASS CLEANING

The Ovation Stove is designed with an advanced air wash system to extend the time between required cleaning of door glass. If the Ovation Stove is operated continuously with the combustion air damper partially or fully closed, the door glass will get dirty quicker than when a medium to high fire is fueling the firebox. In order for glass to remain clean, a high temperature fire must be maintained in the firebox (see "Refueling for Optimum Performance," page 14.) **CAUTION:** Do not clean hot glass. If the door glass does require cleaning, use an authorized stove glass cleaner. A Country Flame authorized dealer will be happy to recommend a suitable cleaner. Regular household glass cleaners are not effective in cleaning creosote and other residue from the glass.

DO NOT use abrasives such as steel wool or powder abrasives as they will permanently damage the glass. Once the glass has been scratched, complete replacement of the glass will be required. Use only approved 1400 degree Fahrenheit (°F) high temperature stove ceramic glass to replace any cracked or broken glass.

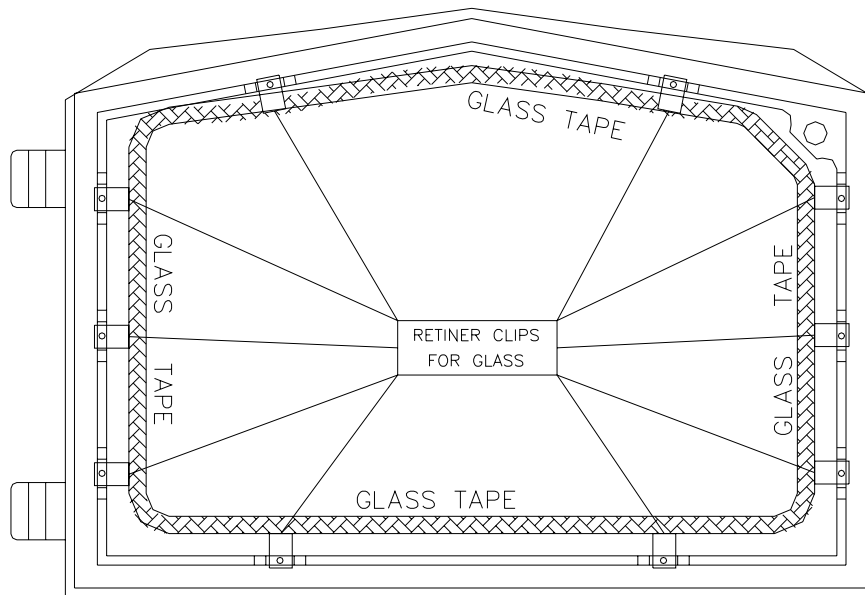

FIGURE 8: DOOR GLASS REPLACEMENT

GLASS REPLACEMENT

The glass used in the Ovation stove is a 1400 degree Fahrenheit (° F) high temperature ceramic glass. If the glass should crack or break for any reason, it must be replaced with an equal or better grade ceramic glass. The use of tempered glass or ordinary glass IS NOT AUTHORIZED and is hazardous to use. Ovation replacement glass can be purchased from an authorized Country Flame dealer. See FIGURE 8 for securing points for the door glass.

GLASS-CERAMIC SPECIFICATIONS

Manufacturer
Window Type

Euro Kera
Glass-Ceramic, Kera Lite®

KERA LITE® glass-ceramic has a thermal endurance far exceeding that of normal tempered glass. **KERA LITE®** is designed to operate at temperatures ranging from **-400°F to +1400°F**. Despite its superior thermal properties, **KERA LITE®** stove windows should be treated with care. This glass-ceramic can still be scratched or broken by mechanical abuse. When cleaning the window, use only non-caustic, non-abrasive cleaners. Ovation stoves use **KERA LITE®** glass-ceramic that is 0.197 inches thick +/- 0.008 inches. Country Flame custom cuts each **KERA LITE®** glass at its factory to fit Ovation stoves. If problems occur or your glass needs replacement, contact Country Flame or a local authorized dealer for assistance in replacing the glass.

CAUTION: Do not attempt to clean hot glass. Do not abuse, strike, slam shut, or operate the Ovation stove with any broken glass in the appliance.

GASKET REPLACEMENT

Remove the doors from the unit. Place the doors, face down on a protective surface to ensure no marring or scratching occurs during gasket replacement. To replace the Thermoglass™ knitted rope and tape gasket, first remove all of the old material and gasket cement. Use a putty knife or other sharp instrument to assist in removal. Use caution to prevent injury when removing old material. It is important to ensure the doorframe area is totally clean before installing the new gasket cement and material. The gasket must fit tight against the doorframe in order to ensure a proper airtight seal when the stove is being operated. Apply gasket cement to the gasket channel per instructions provided with the gasket kit. Once the cement has been properly applied, install the new gasket. Both gasket and gasket cement are available from your authorized Country Flame dealer. The following table defines the gasket material used in the Ovation stove:

<u>Gasket</u>	<u>Length</u>	<u>Quantity</u>	<u>Dimensions</u>
Around glass	4.25 feet each	2	3/4" wide by 1/16" thick tape
Doorframe	5 feet each	2	3/8" rope, high density
Ash drawer	30 inches	1	1/2" wide by 1/8" thick tape

CLEARANCES

Table 1 is used to determine clearances for the stove installation based on whether a single or double-wall connector is used from the appliance to the chimney.

DISTANCES	SINGLE-WALL PIPE			DOUBLE-WALL PIPE* ALL MODELS
	OV-1700 & 2100	OV-2600	OV-3000	
A. SIDEWALL TO UNIT	19"	20"	22"	14"
B. BACK WALL TO UNIT	10"	12"	12"	5"
C. CORNER TO UNIT	6"	6"	8"	2"
D. SIDEWALL TO CONNECTOR	28"	29"	31"	23"
E. BACK WALL TO CONNECTOR	13"	16.5"	16.5"	9"
F. CORNER TO CONNECTOR	16"	16.5"	19"	11.5"

TABLE 1: REQUIRED CLEARANCES

* Factory-built chimney systems should use a chimney UL Listed to 103HT or equivalent product in the United States. For Canada, use chimney listed to ULCS629.

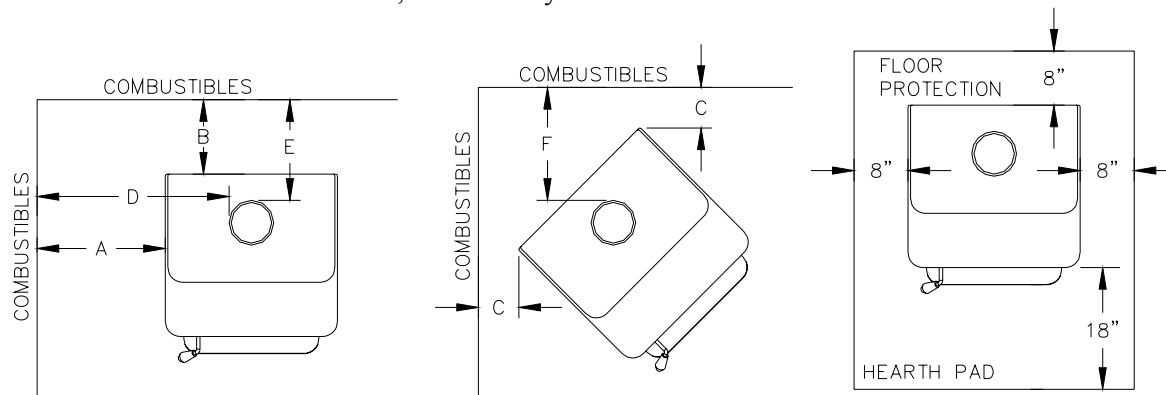

FIGURE 9: FREESTANDING CLEARANCE REQUIREMENTS

CHIMNEY

It is extremely important that an Ovation stove be vented into a non defective, clean, and properly lined masonry chimney. The masonry chimney system must conform to all local building codes. In the event a masonry chimney is not used, a listed factory-built chimney suitable for use with solid fuels should be used. This listed factory-built chimney system must conform to ULC-S629 (Canada) or UL 103HT (United States.) FIGURE 9 shows clearances required for various freestanding installations of Ovation stoves.

Connect the Ovation appliance to an approved chimney system with a connection as short as possible using six inch (150mm), 24 gauge or heavier, single or double-wall black or blued steel smoke pipe. Attachments and connections of the chimney sections should be completed with a minimum of three sheet metal screws to the stove and to each adjoining section. Connection to a masonry chimney must be by a metal or masonry thimble cemented in place. All chimney connectors must slope upwards, ¼" rise per foot. If passing through a combustible wall, a UL Listed insulated wall thimble must be used. The total chimney connector length should not exceed 40% of the chimney height above the stove. **DO NOT CONNECT ANY OVATION APPLIANCE TO A CHIMNEY FLUE SERVING ANOTHER APPLIANCE.**

FIGURE 10, FIGURE 11, and FIGURE 12 illustrate various chimney connections for both masonry and factory-built chimney applications. If installations require something different than one of these illustrated methodologies, please contact a local code official and a professional installer to ensure the proposed installation is code approved.

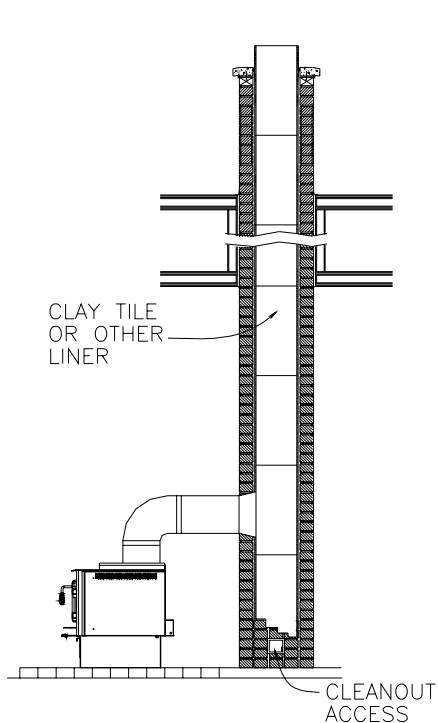

FIGURE 10: MASONRY CHIMNEY

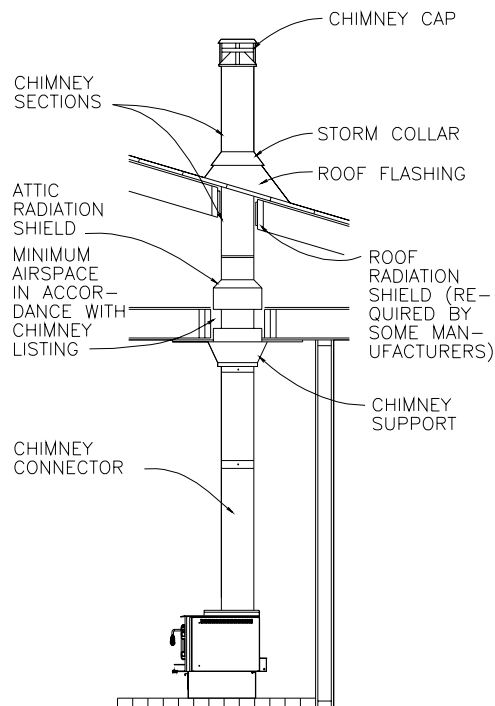

FIGURE 11: CEILING SUPPORT (interior)

FACTORY-BUILT CHIMNEY

For any factory-built chimney installation, in conjunction with an Ovation freestanding woodstove, the homeowner should refer to the chimney manufacturer's instructions. It is important that in addition to manufacturer's instructions, the homeowner follow all national and local codes during the installation process.

The freestanding clearances for unshielded (single-wall) combustible applications, listed in TABLE 1, page 24, must be maintained. If local code allows, these distances can be reduced when acceptable shielding is provided. Consult a local code authority and professional installer to ensure that a specific installation meets proper code.

MASONRY BUILT CHIMNEY

Before connecting this stove to your chimney, be sure to have the chimney inspected by a chimney professional and cleaned, if necessary. The chimney must have a liner that is free from cracks, deterioration, softening, or other damage that may prevent it from containing the byproducts of combustion. In the event of damage, the flue must be relined with a listed liner system, such as HomeSaver Chimney Liner. If your masonry built chimney contains oversized flue tiles it must be relined to ensure proper draft. For six-inch woodstove flues, a chimney tile size of eight by eight or a nine by thirteen inch interior tile dimension may be used without chimney relining provided excessive creosote deposits are not present. In the event an application using larger chimney tile size is encountered, a new, properly sized liner system must be installed before connection to the woodstove's six-inch flue is completed.

CAUTION: When installation requires connection from a woodstove flue through a combustible wall to a masonry chimney a UL Listed thimble (wall penetration system) must be utilized. FIGURE 14, page 29, show an optional thimble installation. Always refer to local codes and a professional installer to ensure a proper flue system. Country Flame also recommends the use of smoke and carbon monoxide detectors when installing an Ovation appliance.

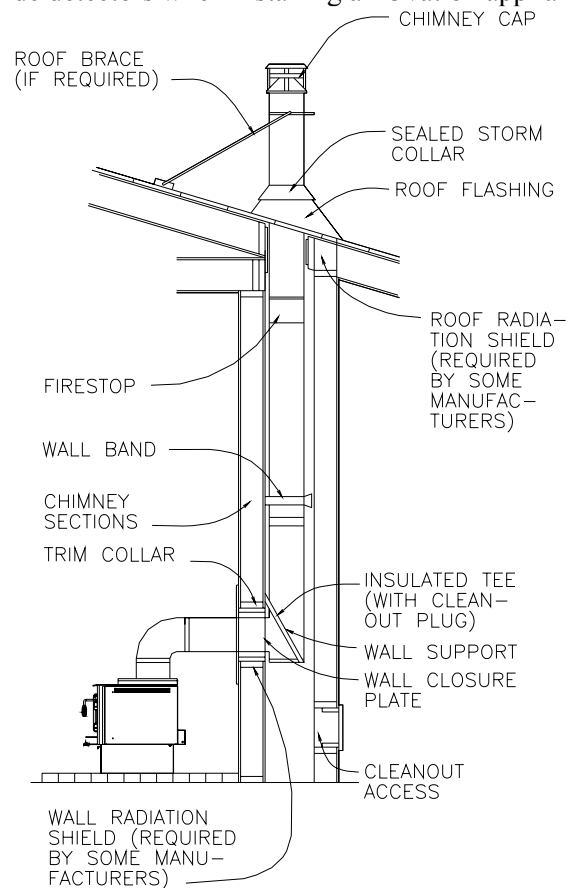

FIGURE 12: WALL SUPPORT (exterior)

ALCOVE INSTALLATION

All freestanding Ovation stove models are approved for alcove installation using double-wall chimney pipe. An alcove must not be greater than four feet deep as measured from the alcove face wall to the alcove back wall. In addition, the alcove must have at least seven feet of clearance when measured from the floor to the alcove ceiling. In an alcove installation, side clearances of fourteen inches from the stove to combustibles and rear clearances of six inches from the stove to combustibles must be maintained as a minimum. Alcove clearances require the use of listed UL 103 or listed ULC S629 Type HT (2100°F) double wall chimney pipe to establish clearances according to FIGURE 13 as shown in TABLE 2. Contact a local building professional or building inspector to obtain information on any local code requirements for such installation.

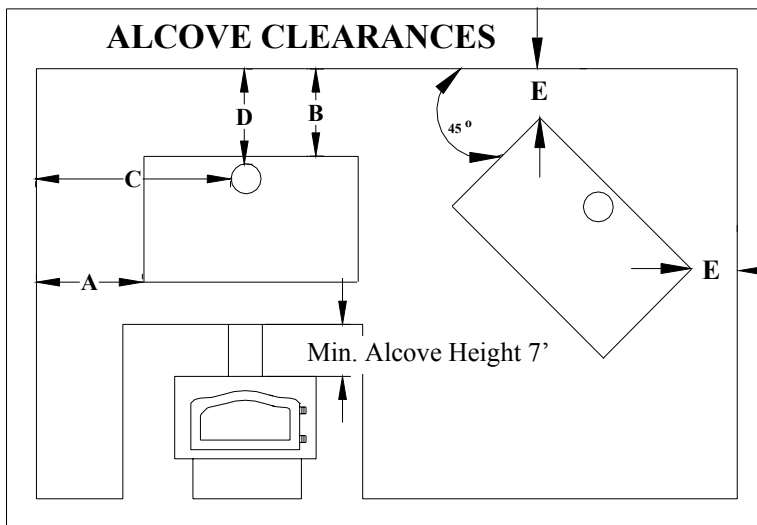

FIGURE 13: ALCOVE CLEARANCES

MODEL	A	B	C	D
Ovation (All Models)	14	6	23	9

TABLE 2: ALCOVE CLEARANCES, IN INCHES

FLOOR PROTECTION REQUIREMENTS

1. All Country Flame freestanding Ovation stoves require a listed floor protector that is noncombustible. Country Flame Ovation stoves were tested with a listed floor protection that had an R value equal to or greater than 1.5. Ensure that any floor protection equals or exceeds $R = 1.5$ or greater. Refer to FIGURE 9 for floor protector clearance requirements.
2. If a floor protector, different from the tested floor protector, is to be used, it must meet or exceed the requirements of the listed R-value of the tested floor protector. To convert alternate floor protectors to their respective R value use the following procedures:
 - a. Convert floor material specification to R-value.
 - i. R-value is given – no conversion is required.
 - ii. k-factor is given with required thickness (T) in inches: $R = (1/k) \times T$.
 - iii. C-factor given: $R = 1/C$.
 - b. Determine the R-value of the proposed alternate floor protector.

- i. Use the formulas provided in STEP 2a to convert values not expressed as “R.”
- ii. For multiple layers of material, add each R-value of each layer to determine the materials overall R-Value.
- c. If the overall R-value of the alternate material is greater than the R-value tested material defined in STEP 1, then the alternate floor protection is acceptable.
- d. **EXAMPLE:**
 - i. The tested material was ¾-inch thick with a k-factor of 0.84.
 - ii. The R-value of the tested material was $R = (1/0.84) \times 3/4 = 0.893$.
 - iii. The proposed alternative floor protector is 4-inch brick material with a C-factor of 1.25 over 1/8-inch mineral board with k-factor of .29.
 - iv. The 4-inch brick material has a value of $R_{\text{brick}} = (1/1.25) = 0.80$.
 - v. The mineral board has a value of $R_{\text{mnbrd}} = 1/0.29 \times 0.125 = 0.431$
 - vi. Total $R_{\text{brick}} + R_{\text{mnbrd}} = 0.80 + 0.431 = 1.231$.
 - vii. Since the total R-value of the alternate example floor protector (R=1.231) is greater than the tested example floor protector (R=0.893), the alternate is acceptable.

3. Listed Floor Protector Definitions:

a. Thermal Conductance = $C = \text{Btu}/(\text{hr})(\text{ft}^2)(^{\circ}\text{F}) = \text{W}/(\text{m}^2)(^{\circ}\text{K})$

b. Thermal Conductivity = $k = (\text{Btu})(\text{inch})/(\text{hr})(\text{ft}^2)(^{\circ}\text{F}) = \text{W}/(\text{m})(^{\circ}\text{K}) = \text{Btu}/(\text{hr})(\text{ft})(^{\circ}\text{F})$

c. Thermal Resistance = $R = (\text{ft}^2)(\text{hr})(^{\circ}\text{F})/\text{Btu} = (\text{m}^2)(^{\circ}\text{K})/\text{W}$

4. Install in accordance with 24 CFR, Part 3280 (HUD).

5. **WARNING:** Ovation stoves must always be placed on a listed floor protector if the existing floor where the stove is to be placed is made of any combustible material. ***IF THE AREA WHERE THE STOVE IS TO BE PLACED IS CARPETED, THE CARPET MUST BE REMOVED. A LISTED FLOOR PROTECTOR IS NEVER TO BE PLACED ON CARPET. CHECK LOCAL CODES FOR ADDITIONAL CARPET RESTRICTIONS AND FLOOR PROTECTION REQUIREMENTS.***

THIMBLE INSTALLATION

Ovation Stove installations that require a connection from the stove through a combustible wall to a masonry chimney require either a UL Listed thimble (wall penetration assemblies) or the methods outlined in the National Fire Association Standard 211, which is outlined below. It is important that the homeowner or installer be well versed in these variations and understands which one is best suited for their application. The following diagrams provide examples and explanations of chimney connector systems and clearances from combustible walls for residential heating appliances. During any installation, it is important to consult with the local code authority or an installation professional to ensure your installation is properly done. The following additional requirements will apply to FIGURES 14 through 17:

- 1. Insulation material used as part of wall pass-through systems shall be of noncombustible material and shall have a thermal conductivity of 1.0 Btu-in./hr-ft²-°F (4.88 kg-cal/hr-m²-°C) or less.

2. All clearances and thicknesses are minimums; larger clearances and thicknesses shall be permitted.
3. Any material used to close up an opening for the connector shall be of noncombustible material.
4. A connector to a masonry chimney, except for the installation shown in FIGURE 15, shall extend in one continuous piece through the wall pass-through system and the chimney wall to the inner face of the flue liner, but not beyond.
5. A chimney connector shall not pass through an attic, roof space, closet, floor, ceiling, or similar concealed space. Where passage through a wall or partition of combustible construction is needed, the installation shall conform to CAN/CSA-B365.

NOTES

1. Minimum chimney clearance from masonry to brick, sheet steel supports, and combustibles 2 in.
2. Masonry chimneys constructed to NFPA 211.

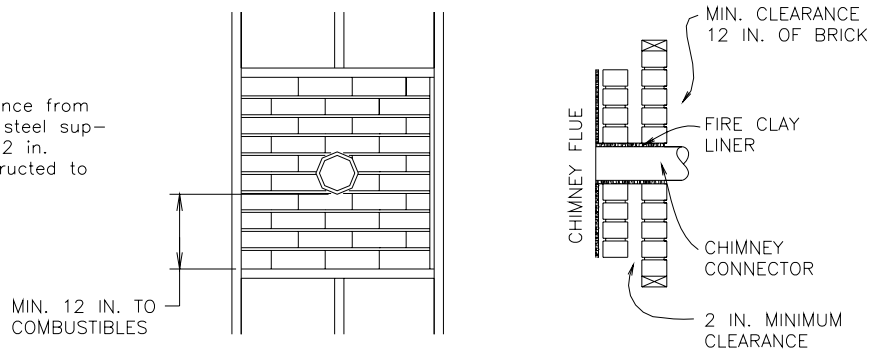

FIGURE 14: MASONRY CHIMNEY TO COMBUSTIBLE WALL

A minimum of three and one-half inch thick brick masonry chimney framed into a combustible wall with a minimum of twelve-inch brick separation from the clay liner to combustibles is permissible. The clay liner (stove) shall run from the outer surface of the brick wall, but not beyond the inner surface of chimney flue liner. The clay liner should be firmly located and firmly cemented in its proper location.

NOTES

1. Minimum chimney clearance from masonry to brick, sheet steel supports, and combustibles 2 in.
2. Masonry chimneys constructed to NFPA 211.

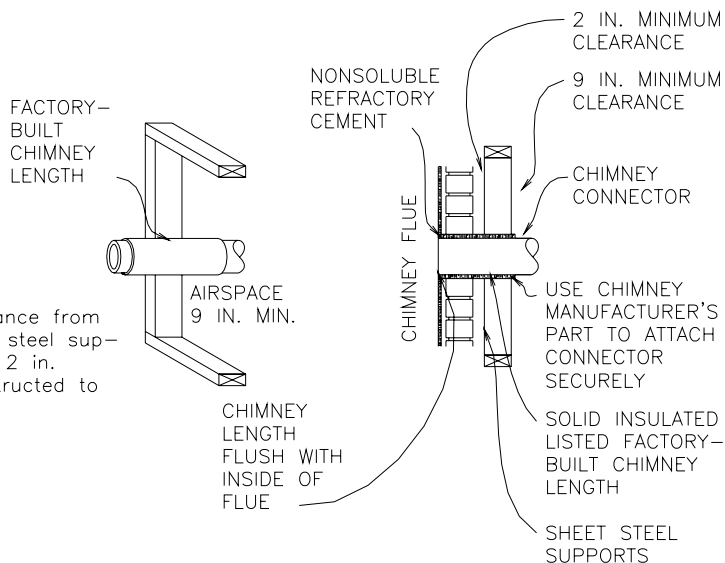

FIGURE 15: TYPE HT 2100⁰ FACTORY-BUILT CHIMNEY

Type HT 2100⁰ factory-built chimney length that has the same inside diameter as the chimney connector. The factory-built chimney must also have one inch or more insulation with a minimum of nine inches of airspace between the outer wall of the chimney length and any combustibles.

NOTES

1. Minimum chimney clearance from masonry to brick, sheet steel supports, and combustibles 2 in.
2. Masonry chimneys constructed to NFPA 211.

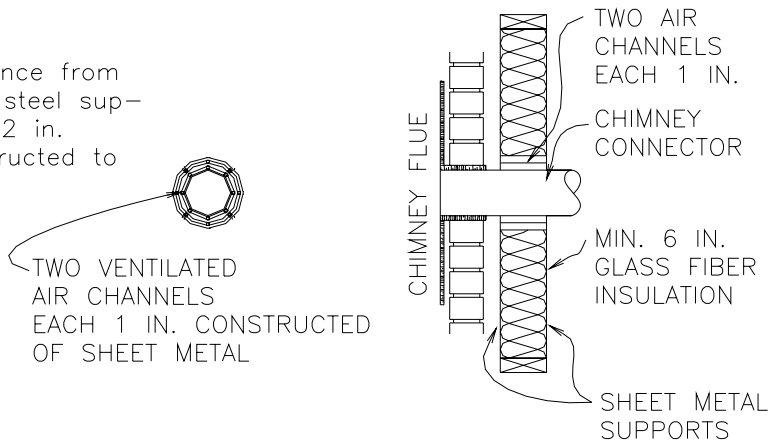

FIGURE 16: SHEET STEEL CHIMNEY CONNECTOR, VENTILATED THIMBLE

A sheet steel chimney connector must be made from material a minimum 24 gauge thick. These connectors must be separated by two, one-inch air channels. The outside of the air channel must be separated from combustible materials by a minimum of six inches of glass fiber insulation. The wall opening shall be covered and the thimble will be supported with sheet steel supports that are made from material at least 24 gauge in thickness.

NOTES

1. Minimum chimney clearance from masonry to brick, sheet steel supports, and combustibles 2 in.
2. Masonry chimneys constructed to NFPA 211.

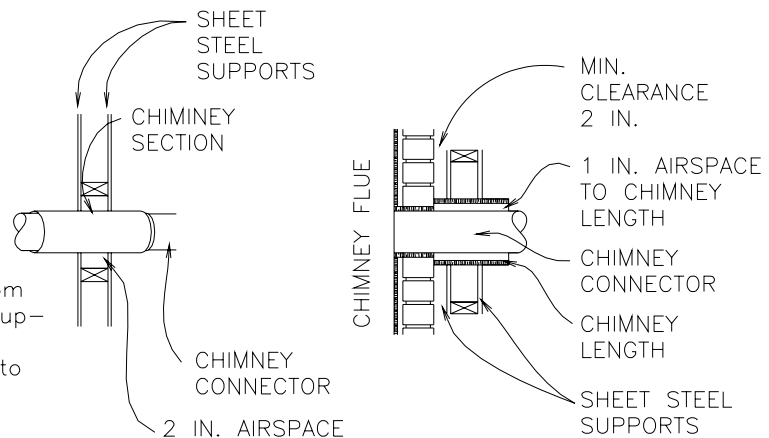

FIGURE 17: TYPE HT 2100⁰ FACTORY-BUILT CHIMNEY

Installations that use type HT 2100⁰ listed factory-built chimney require an inside diameter two inches larger than the chimney connector. This listed chimney must have at least one inch or more insulation which serves as a pass-through for a single-wall sheet steel chimney connector that is a minimum 24 gauge thick and with a minimum two inch space between the outer wall of chimney section and any combustibles. The minimum length of the chimney section must be twelve inches and that chimney section will be spaced one inch away from the connector using sheet steel support plates at both ends of chimney section. The opening shall be covered and the chimney section supported on both sides with

sheet steel supports that is a minimum of 24-gauge thickness and is securely fastened to the wall surfaces. Any fasteners used to secure the chimney section shall not penetrate any portion of the chimney flue liner. A minimum of three screws per chimney connector must be used.

A chimney connector shall not pass through an attic, roof space, closet, floor, ceiling, or similar concealed space. Where passage through a wall or partition of combustible construction is desired or necessary, the installation shall conform to CAN/CSA-B365.

Whatever brand of chimney system is purchased for your Ovation installation, you must ensure that all chimney manufacturer's installation instructions are followed and that all national and local codes have been met.

OUTSIDE AIR COMBUSTION

It is imperative that the installer or homeowner ensures that a minimum of at least eight square inches (fifty square centimeters) of outside air be admitted to the hearth room or directly to the stove. If installation allows, a four-inch diameter pipe can be brought in through an exterior wall and connected to the freestanding Ovation stove using the optional fresh air adapter.

Provision for outside combustion air may be necessary to ensure that fuel-burning appliances do not discharge byproducts of combustion into the house. Guidelines to determine the need for additional combustion air may not be adequate for every situation. If in doubt, it is advisable to provide outside air.

Outside combustion air may be required if:

1. The Ovation stove does not draw steadily, smoke rollout occurs, fuel burns poorly, or back-drafts occur whether or not combustion is present.
2. Existing fuel-fired equipment in the house, such as fireplaces or other heating appliances smell, do not operate properly, suffer smoke rollout when opened, or back-draft occurs whether or not combustion is present.
3. The home is equipped with a well-sealed vapor barrier and tight fitting windows or has any powered devices that exhaust house air.
4. There is excessive condensation on home windows in the winter.
5. A ventilation system is installed in the house.

If any of these or other indicators suggests that infiltration air is inadequate, additional combustion air should be provided from the outdoors to the Ovation appliance. Outside combustion air can be provided to the appliance by the following means:

1. Direct connection: appliances can only use direct connection of outside combustion air if they are certified for this type installation. Follow the Ovation instructions for direct connection of outside combustion air.
2. Indirect connection: for appliances not certified for direct connection of outside combustion air, outside air can be ducted to within twelve inches of the appliance.
3. Mechanical ventilation: if the house has a ventilation system (air change or heat recovery):
 - a. The ventilation system may be able to provide sufficient combustion make-up air for the Ovation appliance.
 - b. The homeowner should be informed that the ventilation system might need to be re-balanced by a ventilation technician after installation of the Ovation stove.

HEARTH PAD REQUIREMENTS

The Ovation stoves can be installed with a leg set. Inserts require no legs. All Ovation stoves require hearth pad protection. A combustible floor in front of the Ovation stove must be covered with tile, marble, stone or some other non-combustible hearth pad material. FIGURE 9, page 25, illustrate the fireplace and the hearth pad extension relationship. Page 28 explains the calculations required to determine if the non-combustible hearth pad material is adequate. **WARNING:** A hearth pad must be installed in accordance with national or local building codes. All hearth extensions for Ovation stoves must have an R-value of 1.5 or greater to ensure proper floor protection. If thermal conductivity (k-factor) or thermal conductance (C-factor) is used instead of thermal resistance (R factor) then use the relationships as follows **a)** k-factor is given with required thickness (T) in inches as $R = 1/k \times T$ or **b)** C-factor is given as $R = 1/C$.

MOBILE HOME INSTALLATION

WARNING: DO NOT INSTALL A COUNTRY FLAME FREESTANDING OVATION STOVE IN ANY MOBILE HOME SLEEPING ROOM.

WARNING: THE STRUCTURAL INTEGRITY OF THE FLOOR, WALL, CEILING AND ROOF MUST BE MAINTAINED DURING THE INSTALLATION OF A COUNTRY FLAME OVATION STOVE IN A MOBILE HOME.

WARNING: A FREESTANDING OVATION STOVE INSTALLED IN A MOBILE HOME MUST BE COMPLETED IN ACCORDANCE WITH 24 CFR, PART 3280 (HUD).

WARNING: A FREESTANDING OVATION STOVE MUST HAVE ITS LEGS PERMANENTLY BOLTED TO THE FLOOR OF THE MOBILE HOME. FIGURE 10 shows a leg option installation

WARNING: A FREESTANDING OVATION STOVE MUST BE ELECTRICALLY GROUNDED TO THE STEEL FRAME OF A MOBILE HOME.

MOBILE HOME RULES

1. Install only a HUD-approved laboratory tested stove in a mobile home. If the metal tag permanently affixed to a wood burning stove does not specifically state; “mobile home approved to HUD Standard UM-84,” do not install the product in a mobile home. Freestanding Ovation Model OV-2100, OV-2600, and OV-3000 stoves are approved for use in mobile homes. Install all Ovation stoves in accordance with 24 CFR, part 3280 (HUD).
2. A permanent (hard line) combustion fresh air duct system must be installed and connected from the outside of the mobile home directly to the combustion air inlet on an Ovation stove.
3. An Ovation stove must have a listed prefabricated chimney system installed in the mobile home. This chimney system must be properly connected and installed directly from the stove through the roof of the mobile home using only one manufacturer’s chimney products. Follow the chimney manufacturer’s installation instructions to the letter.
4. All mobile home stove installations or stove replacements require a permit to be obtained from the local code department and at least a final inspection before operation of the stove is authorized. Use only licensed contractors to perform the installation work. Further, an insurance representative should provide an approval document stating that the installation and inspection are in accordance with industry standards and therefore covered by the homeowner’s insurance policy.

MOBILE HOME CLEARANCES

1. Clearance is defined as the open space distance between any part of the stove or its flue connector and any combustible material, including but not limited to: walls, ceilings, trim moldings, furniture, word storage containers, or any other combustible item. Refer to the stove clearance section of this manual or the certification tag on a stove for minimum clearances that must be maintained during installation of a stove into a mobile home.

2. Use of an approved thermal barrier may allow for the reduction of no barrier minimum stove clearances. Remember that a wall (wood studs covered with sheetrock, even if that wall is covered with brick) is still considered combustible. Functional thermal barriers are made of hearth pads consisting of two ¼” sheets of mineral board or 24-gauge sheet metal spaced 1” from the combustible wall, with approved spacers that provide additional protection to the combustible wall. Refer to a hearth pad manufacturer’s instructions or the National Fire Protection Association Publication 211. Do not violate minimum clearances with approved thermal barriers. Manville’s CERAFORM 126 is an example of an approved insulated wall protector. This product has a K equal to .27 and is a half-inch thick. Total thermal resistance should exceed 1.5 for any material used to ensure proper thermal protection of a combustible wall.

MOBILE HOME STOVE ATTACHMENT

1. Install combustion air to the bottom of the stove as shown in FIGURE 18 in all mobile home applications. The other end of the combustion air tube is installed through the mobile home floor. Ensure that snow or other material cannot prevent fresh air from entering the duct located outside the mobile home.
2. Install a mesh screen or an approved fresh air cap on the outside of the mobile home combustion air tube. This cap will keep foreign material, birds, or small animals out of the fresh air system. Do not use mesh screen from windows as it has too small a hole.
3. If operation of the Ovation freestanding stove causes room air starvation, dangerous fumes can be sucked into the mobile home from other vented appliances. **WARNING: DO NOT INSTALL ANY OVATION WOOD-BURNING STOVE IN A SLEEPING ROOM.** Air starvation usually occurs: (a) because the combustion air intake is blocked, (b) because the stove door is left open or does not seal properly, or (c) due to strong exhaust fans being operated inside the mobile home. Always ensure that fresh air intake systems remain unblocked and ensure free fresh airflow. Contact your local Country Flame dealer for annual inspections.

FIGURE 18: MOBILE HOME LEG INSTALLATION

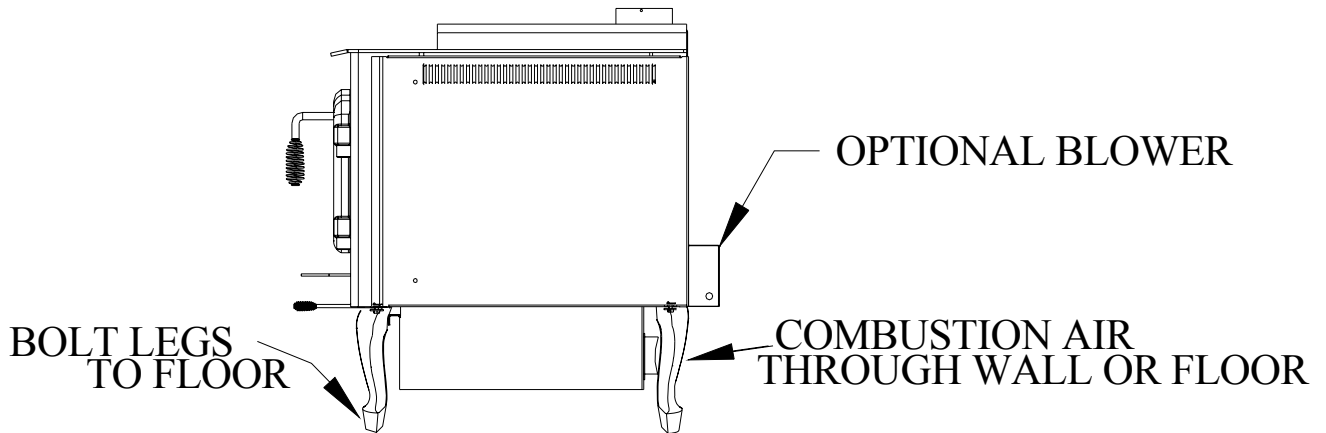

MOBILE HOME FLOOR PROTECTION

1. A mobile home floor must be protected against stray sparks, radiant heat build up, or from damage during general use.
2. This floor protection must meet certain minimum requirements as a thermal barrier. Calculations are provided in this manual for determining if a floor protector meets minimum requirements for a mobile home installation.
3. At no time should a floor protector be placed on top of carpeting. Carpeting must be removed and the floor protection should sit directly on the uncarpeted portion of the mobile home floor. Floor protection should extend to the front, sides, back, and under the chimney connector as defined for a specific model listed in this manual. In the event there are floor protection questions, contact Country Flame or one of its local authorized dealers for assistance.

MOBILE HOME CHIMNEY AND DUCTS

1. ALL chimney connectors, parts, attachments, and ducts should meet UL 103HT standards. One of the UL 103HT criteria is that a chimney component withstands temperatures of 2,100⁰F. Although this UL rating does not guarantee a chimney fire will not occur, it is as close to ideal as industry standards provide today. Mobile home stove and chimney restrictions are that: (a) regular thin walled stovepipe is not permitted, (b) roof systems cannot be weakened when installing a chimney system, (c) a chimney cap and spark arrester are mandatory, and (d) the chimney must be strong enough to withstand normal area wind velocities.
2. There are many chimney manufacturers providing excellent products that meet government listing requirements. From single wall, to double wall, to triple wall

chimney components, each type and brand meets many various application criteria. Further, each chimney manufacturer provides excellent written instructions on HOW TO install a chimney system. This information should aid the homeowner in ensuring a certified professional completes the job properly. If there are questions, contact Country Flame or a local authorized dealer. If additional information is required, a search of the internet will provide plenty of valuable information. An example of an informative and excellent chimney product site is www.duravent.com.

3. A complete chimney system should include a HUD approved spark arresting chimney cap, a storm collar, a roof flashing, an attic radiation shield (if needed), a chimney support box, a ceiling finish collar, an approved chimney connector such as a Security Model DL42A, and other parts required by site specific conditions. There will be clearance differences presented in both the stove and chimney manufacturers' product literature. ALWAYS use the larger clearance requirement when installing a wood burning stove system into a mobile home.
4. A mobile home chimney system should serve only one wood burning stove. The chimney system must extend at least 3 feet above the highest point on the roofline where it passes through the roof. The chimney system should be at least 2 feet higher than any part of a roof or building within a 10-foot clearance around the chimney. Refer to FIGURE 5 for a diagram of the 3 by 2 by 10 foot chimney rule. The minimum chimney vertical height is 8 feet and the maximum chimney vertical height is 25 feet as measured from the top of a specific Ovation model stove to the chimney flue exit. REMEMBER: The structural integrity of a mobile home wall and roof must be maintained during installation of an Ovation stove. Country Flame strongly discourages the removal or cutting of roof trusses or other structural components of a mobile home in order to install a stove. Consult local code.
5. To comply with over-the-road height limitations and to protect the chimney system and roof from damage remove all above roof chimney parts during transport of a motor home. Use only noncombustible material to seal all chimney system joints to prevent cold air leakage into a mobile home. Refer to local codes or with an authorized local Country Flame dealer to obtain the name of approved noncombustible sealants.
6. Many chimney manufacturers provide mobile home chimney kits, such as Dura-Vent's Mobile Home Kit Number 6DP-MH6" STOCK NUMBER 9096N. These mobile home chimney kits are not all-inclusive. A homeowner should consult with a certified professional. Additional chimney parts will be required to handle variations in local codes, site-specific mobile home issues, ceiling height, ceiling slope, roof pitch, attic insulation, attic height, and surrounding objects. Use a certified professional to install a chimney system and do not deviate from a chimney manufacturer's installation instructions. Contact Country Flame or a local authorized dealer to resolve any questions or installation procedures. TABLE 8 shows the required components needed for a typical mobile home installation. Contact a Dura-Vent or other authorized chimney dealer for the latest specifications and the cost of mobile home chimney system parts or a mobile home chimney kit from an authorized chimney dealer.

TABLE 8: MOBILE HOME (minimum) CHIMNEY SYSTEM REQUIRED PARTS

FIGURE 20 ITEM NUMBER	PART NUMBER	DESCRIPTION	QTY
1	SDP-C-9084	SPARK ARRESTOR CHIMNEY CAP	1
4	SDP-F-9049V	0/12 – 6/12 ADJUSTABLE ROOF FLASHING	1
4 (alternate)	SDP-F-9051V	ROOF FLASHING, Flat (vs. SDP-F-9049V)	1
9/10 (alternate)	SDP-S-9047N + TRIM	CEILING SUPPORT BOX, Flat	1
9/10	SDP-SB-9048AN + TRIM	CEILING SUPPORT BOX, Square (vs. SDP-SB-9048AN)	1
2	SDP-P-9121SS	24" CHIMNEY SECTION	2
5	SDP-IS-9946	ATTIC INSULATION SHIELD (ONLY IF NEEDED)	1
8	CERAFORM 126	WALL PROTECTION (IF REQUIRED)	1
3	SDP-SC-9959	STORM COLLAR	1
6/7	DVL-8646	DOUBLE WALL ADJUSTABLE OR FIXED STOVEPIPE	1/2
11	DVL-8674	CLOSE CLEARANCE ADAPATER (not shown, Fig 12)	2

NOTE: The information provided in TABLE 8 and detailed in FIGURE 20 are for informational purposes. These chimney system parts may or may not be needed depending on site specific conditions found in the homeowner's application. Consult a certified professional and insure that any installation meets all federal, state, and local building codes. Failure to follow the chimney manufacturer's installation instructions will void Country Flame's product warranty and can have an adverse impact on the homeowner's insurance policy. Contact Country Flame or one of its local authorized dealers to resolve any questions about installation or parts usage.

FIGURE 20: MOBILE HOME CHIMNEY INSTALLATION

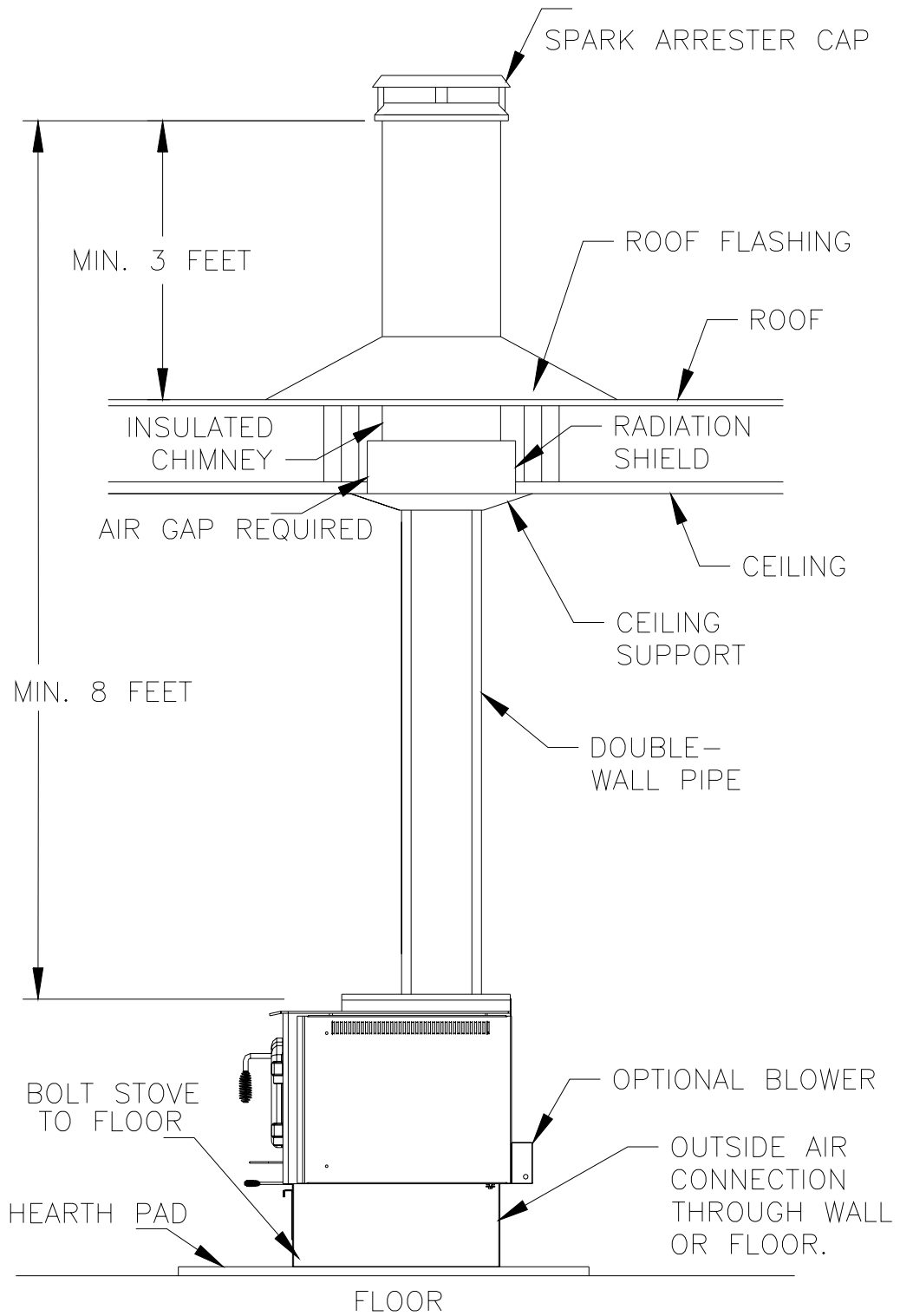

OVATION MODEL OV-26BF-I INSERT (BAY FLAME)

INSTALLATION, GENERAL RULES

Country Flame strongly recommends hiring a certified installer to professionally install your OV26-BF-I Insert. These professionals have been trained and maintain a working knowledge of the latest codes, technology and procedures to ensure a safe and efficient installation. As a minimum, the following installation guidelines should be adhered to:

1. Install the OV26-BF-I insert only in a masonry fireplace or listed zero clearance fireplace that is at least 25 inches wide, 21 inches high, and 14 inches deep. The masonry fireplace should have a UL Listed liner installed in the chimney. The chimney should be at least 15 feet high.
2. The masonry fireplace must be constructed in accordance with local and national building codes. Be sure the fireplace and chimney are clean and sound without any cracks or loose mortar. Do **not** remove bricks or mortar from the wood-burning fireplace to accommodate installation of the Ovation OV26-BF-I insert stove.
3. Have the masonry fireplace and chimney professionally cleaned and inspected before installing the OV26-BF-I Insert.
4. Remove the damper plate or wire the damper plate open with a heavy gauge wire.
5. FIGURE 21 shows a typical OV26-BF-I Insert installed in a masonry fireplace.

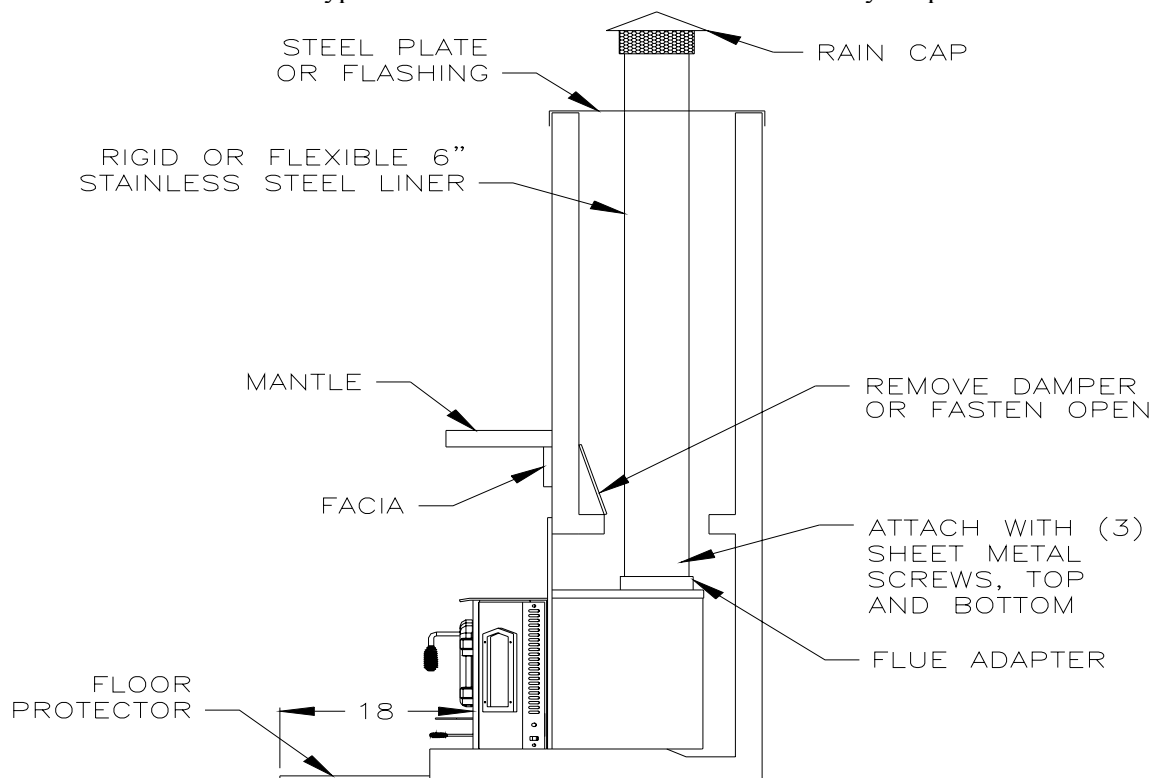

FIGURE 21: OV26-BF-I INSERT

6. Operation and use of electrical assemblies, such as blower motors, should include the care, maintenance, and proper routing of power supply cords following national or local codes for installation of such systems.

Proper draft must be provided for the Ovation OV26-BF-I insert to operate correctly. The amount of draft in any chimney depends on the height of the chimney, the local geography, any nearby obstructions, and other factors. Consult with a local installer or your dealer if you have any concerns about proper draft.

INSTALLATION INTO FACTORY BUILT FIREPLACES

If an Ovation insert is to be installed into a **listed zero clearance** fireplace, the following requirements must be met:

- Installation must include a full height listed chimney liner meeting type HT requirements (2100 degrees F) per UL 1777 (U.S.) or ULC S635 (Canada). The liner must be securely attached to the insert flue collar and chimney top as shown in FIGURE 21.
- Means must be provided to prevent room air passage to the chimney cavity of the fireplace. Sealing the damper area around the chimney liner, or sealing the fireplace front may accomplish this.
- Airflow within and around the fireplace shall not be altered by the installation of the insert (i.e. no louvers or cooling air inlet or outlet ports are blocked), unless specifically tested as such for each factory-built fireplace manufacturer and the model line. (Note – using a louvered faceplate (surround) complies with this requirement).
- Alteration to the fireplace in any manner is not permitted with the following exceptions;
 - a. External trim pieces which do not affect the operation of the fireplace may be removed providing they can be stored on or within the fireplace for reassembly if the insert is removed.
 - b. The chimney damper may be removed to install the chimney liner.
- Circulating air chamber (i.e. in a steel fireplace liner or metal heat circulator) shall not be blocked.
- Means must be provided for the removal of the insert to clean the chimney flue.
- Inserts that project in front of the fireplace must be supplied with appropriate supporting means.

INSTALLATION INTO MASONRY FIREPLACES

When the OV26-BF-I Insert is installed into a masonry fireplace, it is not required to have a full height listed chimney liner, but a full height listed chimney liner it is strongly recommended in order to assure maximum operating efficiency. FIGURE 22 provides an illustration of a full height liner.

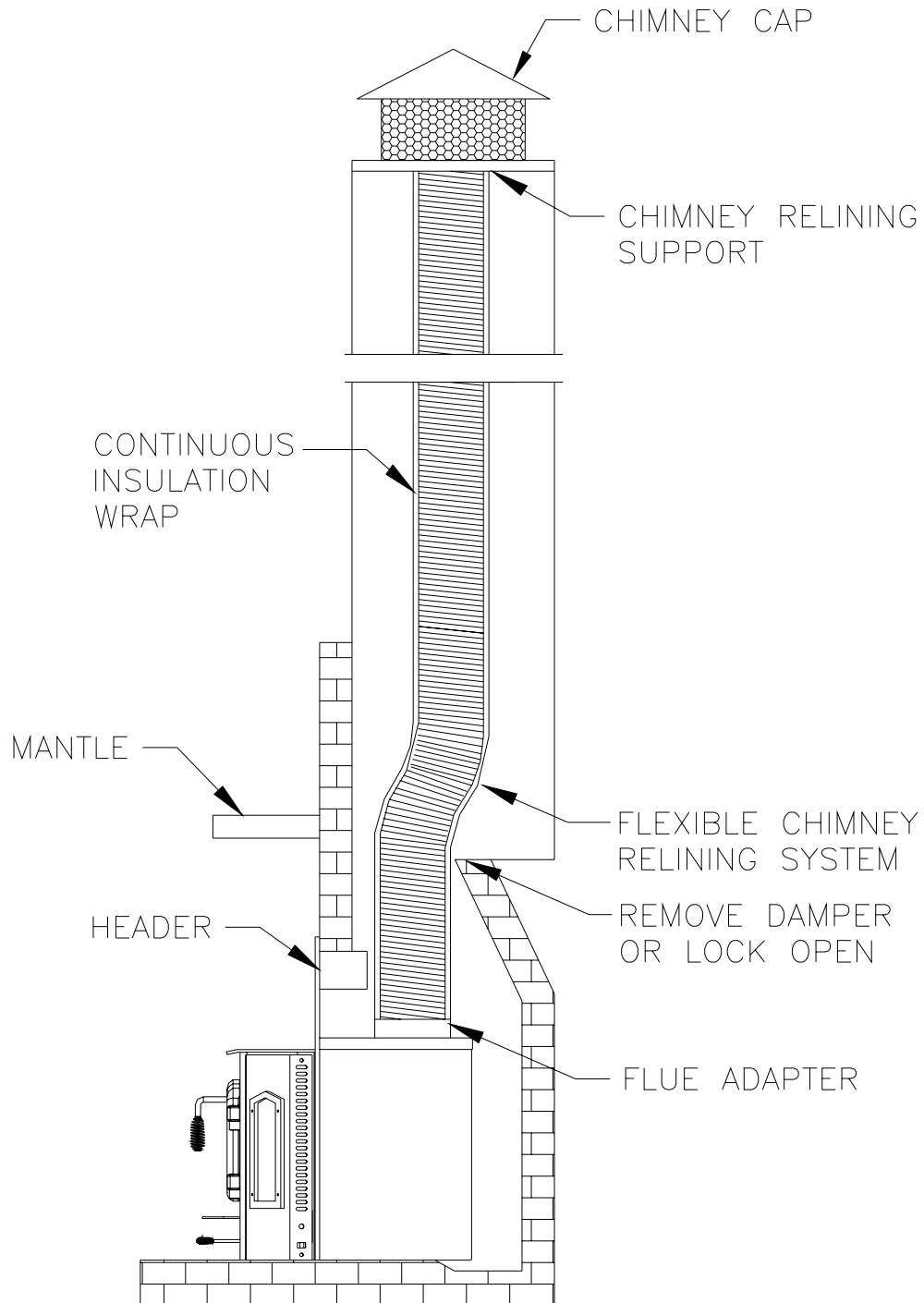

FIGURE 22: FULL HEIGHT LINER

If a full height chimney liner is not used in a masonry chimney, a **DIRECT FLUE CONNECTION** may be used. FIGURE 23 illustrates a direct connect method. An optional low clearance offset flue adaptor may be required to allow proper connection to the chimney. Consult local building codes and the direct flue connection manufacturer's installation guide for restrictions and proper use. Ensure that the proper liner passes above the first clay flue tile joint as shown in Figure 23. NOTE that in Figure 23 the masonry chimney damper assembly has been removed to allow for ease of installation of the steel liner and the direct connect assembly. Always follow the direct connect manufacturer's installation instructions over any information supplied with this manual. Contact Country Flame or one of their local dealers to resolve any questions or for inspection assistance before completing installation.

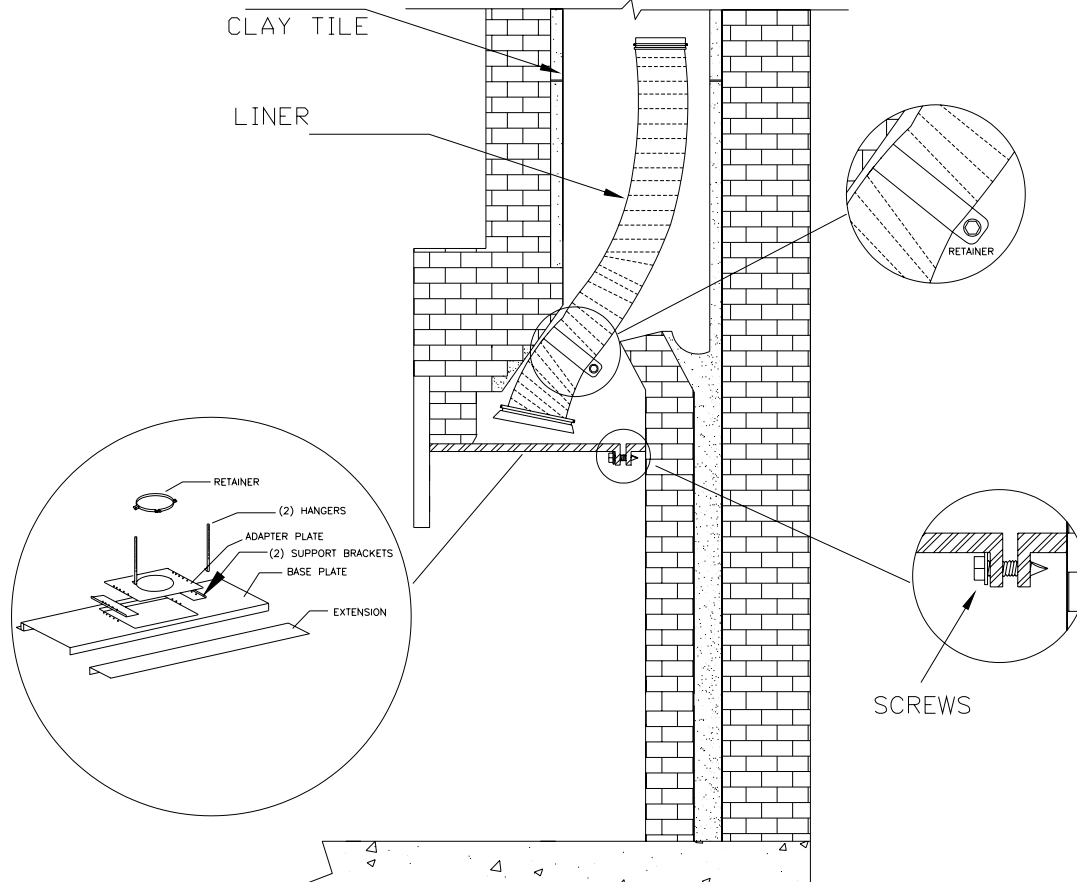

FIGURE 23: DIRECT CONNECT

For a direct connect installation, a damper seal plate is required to be installed in the throat of the fireplace just below the damper plate (remove damper plate). If required, shims may be utilized to support and level the OV26-BF-I Insert into the fireplace, especially if the firebox is lower than the hearth. **DO NOT** install the stove's firebrick until the stove unit is in its final position. The direct connect flue is not as efficient as a full chimney liner but allows for installations that might otherwise be costly or impossible to complete if only a fully chimney liner system were used.

After the OV26-BF-I Insert is properly aligned, supported, and installed, the attachment of the top trim panel and trim pieces can be completed. Place the top trim panel on top of the insert sliding the clips down over the raised metal bar on top of the insert. Ensure that all three-pieces of brass trim fit together and have been slid down completely around the shroud panels. Failure to properly install the brass trim will present an unsightly appearance and will create noise when blower fans are operated.

The top trim piece should align with the side trim panel edges. Refer to the instructions provided with the Country Flame shroud kit.

The OV26-BF-I Insert is factory equipped with two thermostatically controlled blowers. A variable speed control allows the fan speed to be regulated by the homeowner. Also included at the factory is a manual blower thermostat by-pass switch. The use of this by-pass switch ensures the homeowner can continuously operate the fans without regard to thermostat.



FIGURE 24: OVATION (OV-26-BF-I) BAY FLAME INSERT

OV26-BF-I INSERT CLEARANCES

FIGURE 26 shows the required clearances from the OV26-BF-I Insert to any combustible material. These are minimum clearances and additional clearance is acceptable.

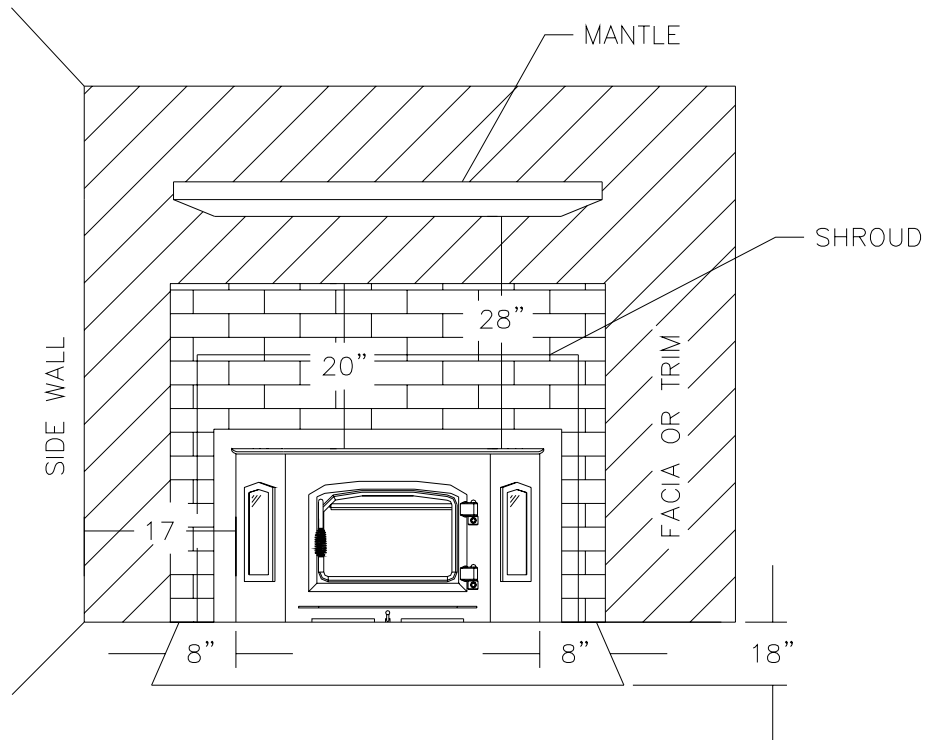
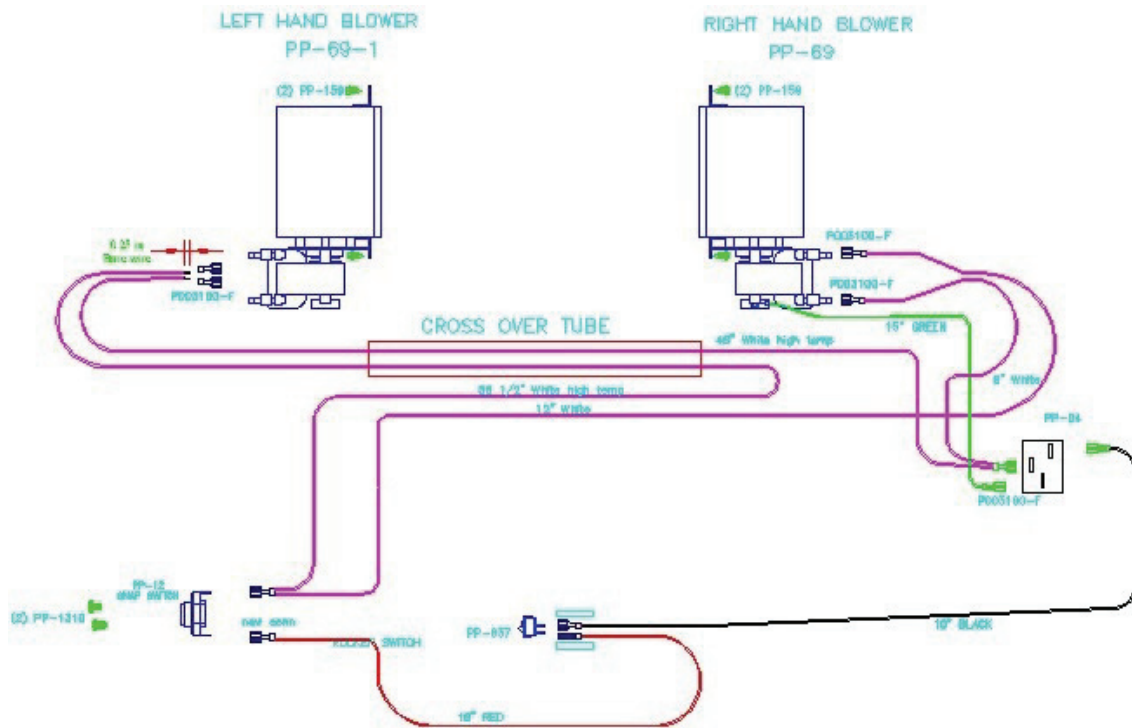

FIGURE 26: INSERT REQUIRED CLEARANCES TO COMBUSTIBLES

CAUTION:

COMBUSTIBLE MATERIALS MUST NOT PROTRUDE MORE THAN 1 INCH TO EACH SIDE OF THE INSERT.

- 1. COMBUSTIBLE FLOORS IN FRONT OF INSERT MUST BE PROTECTED BY A UL LISTED HEARTH PAD EXTENDING 18 INCHES TO THE FRONT AND 8 INCHES FROM THE SIDE OF THE INSERT.**
- 2. A MANTLE (UNSHIELDED) MUST NOT BE INSTALLED CLOSER THAN 28 INCHES TO THE TOP OF THE INSERT.**
- 3. TOP FACING MUST NOT BE INSTALLED CLOSER THAN 20 INCHES TO THE TOP OF THE INSERT.**
- 4. SIDE WALLS (UNSHIELDED) MUST NOT BE INSTALLED CLOSER THAN 17 INCHES TO THE SIDE OF THE INSERT.**



OV26-BF-I ELECTRICAL

FIGURE 27: OV26-BF-I ELECTRICAL DIAGRAM

FIGURE 27 shows the electrical diagram of the dual blower Ovation 26-BF-Insert stove. The snap disk over ride switch allows the operator to test or operate the blower system before the snap disk gets to operating temperature and turns the blower system on. Once the snap disk is heated to operating temperature the over ride switch is ineffective in turning on or off the blower system until the snap disk cools down. The blower system has no user serviceable parts and should only be serviced by a certified technician or an electrician. **WARNING: Hazardous voltages and currents exist in the OV26-BF-I blower system. Ensure the OV26-BF-I is connected to a UL approved and properly grounded electrical outlet. Failure to properly ground the blower system can present electrical hazards to occupants and users of this product.**

HOW IT WORKS

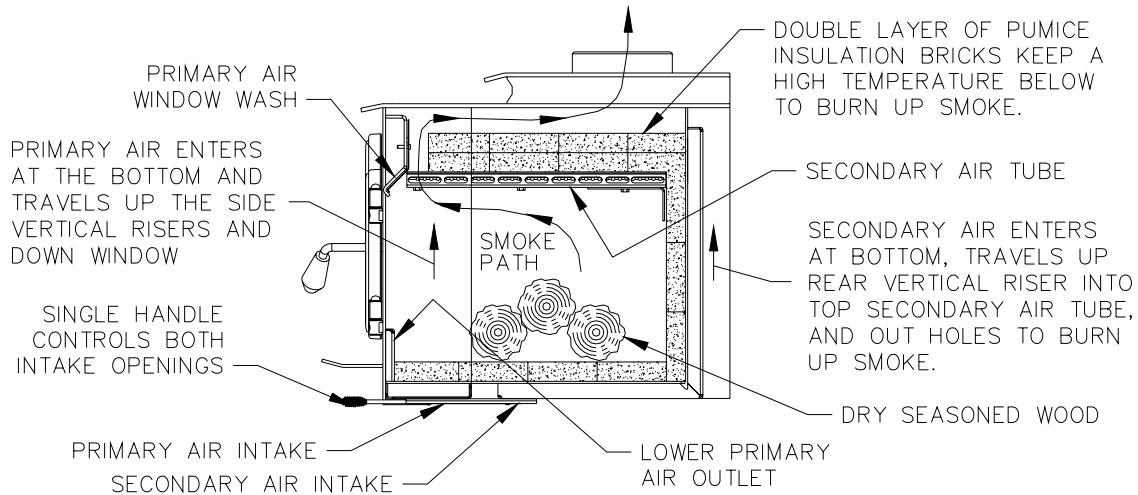

FIGURE 27: OVATION WOOD-BURNING COMBUSTION SYSTEM

WOOD COMBUSTION BASICS

FIGURE 27, above, shows the process by which dry seasoned wood is turned into heat in the Ovation stove. The following information provides some wood combustion basics. An understanding of this process will ensure a lifetime of satisfaction from your Ovation stove. Proper care and maintenance will ensure that the Ovation stove requires minimal maintenance while providing maximum heating comfort for your environment. For specific stove or combustion questions, contact Country Flame or a local authorized dealer.

In a normal wood combustion process as heat is added to start a fire, water is first boiled out of the wood. As moisture is dried from the wood, volatile matter and fixed carbon matter are released and available to be burned to create heat. Any remaining debris left behind in the burn process is defined as ash. FIGURE 28 illustrates the combustion process of wood.

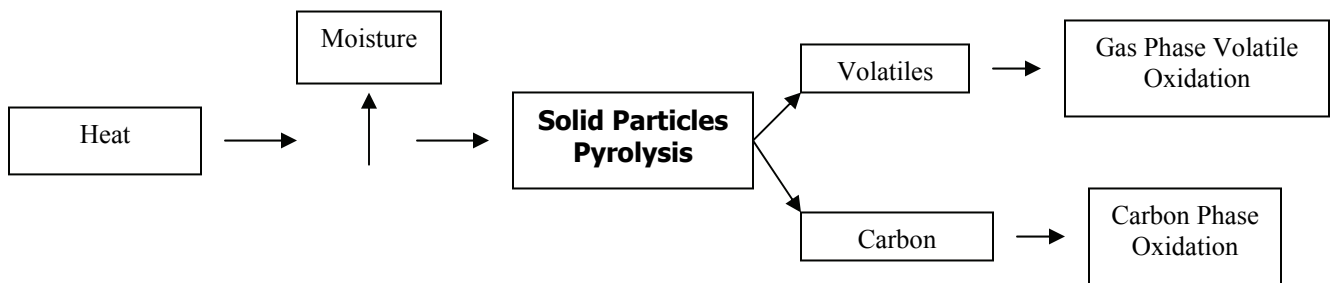

FIGURE 28: WOOD COMBUSTION PROCESS

Based on an understanding of FIGURE 28, it is obvious that properly seasoned dry hardwood provides greater heat energy than moist, green, or softwood. The heat released during the burn process thoroughly warms the firebox, thus sustaining combustion. An Ovation's firebox temperature can approach 2000° Fahrenheit as complete combustion of the exhaust gases occurs. These high temperatures will sustain an efficient burn and ensure that the stove and chimney system remain clean. The list below gives a sample of ignition temperatures for some of the carbon and volatile matters released when wood is burnt:

<u>COMBUSTIBLE</u>	<u>FORMULA</u>	<u>IGNITION TEMP (° F)</u>
Fixed Carbon	C	765 – 1115
<u>Volatiles</u>		
Hydrogen	H ₂	1076 – 1094
Methane	CH ₄	1202 – 1382
Ethylene	C ₂ H ₄	1008 – 1018
Benzene	C ₆ H ₆	1364
Ethane	C ₂ H ₆	968 – 1166
Carbon Monoxide	CO	1191 – 1216

Note that all **ignition temperatures for volatile matters given off by wood** fall between 950° F through 1400° F. All visible flame emitted during a wood fire come from the ignition of volatile matter. Good clean combustion occurs when the volatile wood fuel vapors are thoroughly mixed with fresh combustion air. It is critical that enough combustion fresh air is available to the stove during the burn process. Proper mixing of the fuel and air ensures all fuel molecules come in contact with oxygen molecules. An abundant amount of oxygen molecules react with the fuel molecules; otherwise, an incomplete burn will occur. NOTE: The fuel-air mixture must ensure combustion temperatures are always maintained as well as exceed the ignition temperature if a continuous burn is to be sustained. It also takes time for the reaction to proceed. It is commonly stated that good conditions for combustion are defined as the THREE T's:

Turbulence _____ Temperature _____ Time

Good combustion requires turbulence in the fuel-air path to ensure that fuel and air molecules are thoroughly mixed to ensure a complete burn process. It takes a certain temperature, defined as Ignition Temperature, to sustain combustion. As volatile gases and carbon matter are released from the wood fuel, they require time to combine with the oxygen in the air. The combustion process is self-sustaining only if all conditions are met.

Heat is obtained from a stove by the thermal radiation that occurs from the burning of wood. Although a fairly complex phenomena to define, the heat radiated from the fire is a very strong function of the local (firebox chamber) temperature and the overall combustion temperature that is maintained within a stove's burn chamber. A relatively minor combustion temperature increase in a wood stove can produce a significant amount of increased heat output. NOTE: The reverse of the preceding statement is also true. That is, if too much heat is pulled from the combustion chamber via heat exchanger tubes, the combustion temperature can drop rapidly. This rapid drop of temperature will cause a

“burn out” because the combustion chamber will drop below the critical “ignition temperature” required to ensure the release of volatile gases from the wood. Seasoned wood, because of its dryness and low burning temperature will ensure an ample supply of volatile and carbon matters available for a continued burn process.

As a final note, the four basic stages of wood burning are:

- a) Up to 212° F moisture is being boiled out of the wood fuel.
- b) Around 575° F gasification of the solid wood fuel occurs. The wood will simply seem to disappear. Very little energy is released in these first two stages and external energy (small kindling) must be used to sustain any combustion that is occurring.
- c) Somewhere between 900° F and 1100° F the gasified wood fuel molecules have combined with oxygen molecules, ignite and release the majority of the available heat energy. Some gases will still not have reached ignition temperature. At this critical stage, if too much heat is removed from the combustion chamber, no more fuel will be burnt. All remaining gasified fuel will simply exhaust through the chimney system as unburned material and the fire will potentially burn out.
- d) At temperatures around 1500° F, the remaining gases and tars will burn off in the combustion chamber. This final combustion yields an additional 10 to 20% additional heat energy and gives a very clean final exhaust from the burn process.

An Ovation stove, when used with seasoned wood, a proper chimney system, and sufficient fresh combustion air, will efficiently perform providing a significant amount of heat to a home. Proper maintenance and service will ensure a lifetime of benefit from this product.

APPENDIX A: SPECIFICATIONS

ITEM	OV-1700	OV-2100	OV-2600	OV-3000	OV26-BF-I
WIDTH x DEPTH	25.5" x 21"	25.5" x 21"	215.5" x 26"	25.5" x 30.5"	25.5" x 26"
HEIGHT ON LEGS	28"	28"	28"	28.75"	20"*
FIREBOX CAPACITY (CU/FT)	1.7	1.7	2.3	3.1	2.3
EMISSIONS (GR/HR)	4.1	4.1	3.7	2.8	3.7
BTU (cordwood**)	55,000	55,000	65,000	75,000	65,000
WEIGHT (LBS)	295	305	400	410	430
HEATING CAPACITY (SQ/FT***)	600-1200	600-1200	1000-1800	1500-2500	1000-1800
BURN TIME (LOW BURN****)	8 hours	8 hours	10 hours	12 hours	10 hours
LOG SIZE	18 inches	18 inches	18 inches	22 inches	18 inches
FLUE DIAMETER	6 inches	6 inches	6 inches	6 inches	6 inches
MOBILE HOME APPROVED	YES	YES	YES	YES	NO
ASH PAN	NO	YES	YES	YES	NO

- * Insert height is shorter because it has no legs
- ** Estimated BTU'S on hardwood test with continued loading.
- *** Figures will vary considerably with fuel and conditions.
- **** Based on continued burning at low air setting, not recommended as it causes excess creosote buildup.

CERTIFICATION: These stoves have been tested and listed by E.E.M.C. to EPA standards and also by ITS/Warnock Hersey to the following standards:

CSA B366.2

ULC 2627

ULC S628

UL 1482

UL 907

APPENDIX B: OPERATING TIPS

Always start a fire with small kindling. The small fire will heat the chimney and improve draft as wood is added to the fire. Add small amounts of wood until the stove is hot. As the stove reaches operating temperature add slightly larger pieces of split wood. Several medium size split logs will burn better than a few large logs. Once the fire is well established and at operating temperature ensuring a proper draft, the firebox can be filled with wood at a level equal to the top edge of the door.

It may take two to three days of normal burning to fully cure the firebrick and get the optimum performance from your stove. Paint curing is something that takes a slow burn process over several small fires. Ensure that you have read the information on paint curing that is provided with this manual and the stove. A mild odor may occur from the paint curing so be prepared to open a window for venting purposes.

Sliding the damper rod, located at the front of the stove under the ash lip, in and out, controls the draft on the Ovation stove. In the fully “in” position, the firebox will be limited to a minimum draft. In the fully “out” position, the firebox will receive maximum draft (high burn). Do not operate any stove on “high burn” for extended periods of time (no more than 1 hour) as over burning can damage the firebox.

Well-engineered, high-tech, tight draft stoves are more sensitive to draft problems. Higher efficiency ratings means more heat is going into your home with less energy being wasted through the chimney system. At the same time, a cold chimney will not draw as well as a hot chimney system. During start up, a cold flue requires the operator to ensure the damper control is in the fully open position (pulled all the way out). After lighting the fire, leave door open about a half an inch until the stove has reached operating temperature. At that time, close the door and shut down the damper slightly. CAUTION: Never leave any fire unattended.

Ovation stoves perform best by burning dry (seasoned) split wood. Burning freshly cut (green) wood will decrease the heat output of the stove because much of the firebox heat is used to dry the unseasoned wood resulting in less heat for the firebox and your home. It is very difficult to establish a fire with “green” wood.

If your Ovation stove has been purchased with a gold door option, ensure cleaning of the gold surface is accomplished before firing the stove. If this is not done, permanent damage can be done to the gold finish. NEVER use an abrasive cleaner on the gold surface. Clean gold door and trim surfaces with a glass cleaner such as Windex or approved gold cleaning solution.

Cleaning the ashes from the firebox is achieved by holding down the spring-loaded lever located under the ash lip on the front of the stove. Hold down the lever while using an ash shovel to drag the ashes to the ash dump so they will fall into the ash pan below. Always leave at least one inch of ash in the stove to assist in insulating the firebrick from the intense heat generated by the wood sitting on the brick. Avoid putting hot coals into the ash pan. **NEVER BURN THE STOVE WITH THE ASH PAN OPEN.** Make sure stove is cool before cleaning out the ashes. The glass may get some creosote buildup on it during low burns but this material should burn clean when the stove is burned at a higher temperature.

You may use the top of the stove for cooking purposes. There are two levels on the top of the stove to give you two cooking surface temperatures.

APPENDIX C: REPLACEMENT PARTS

PART NUMBER	DESCRIPTION
PP-868	Firebrick (Specify number)
OV-101	Brick Bracket (Back)
OV-109	Brick Bracket (Sides)
PP-902	Gasket Rope Replacement (4.5 ft)
PP-88	Gasket Tape Seal for Glass (4 ft)
PP-391	Sodium Silicate Glue (for Door Rope Gasket)
PP-48	Glass - 15 ½" x 11" (Plain)
PP-525	Glass - 15 ½" x 11" (Etched)
PP-53	Side Glass - 3 ½" x 11" (Plain)
PP-54	Right Hand Side Glass - 3 ½" x 11" (Etched)
PP-65	Left Hand Side Glass - 3 ½" x 11" (Etched)
PP-935	Ash Pan Latch Handle Assembly
PP-878	Spring Handle
PP-79	Blower Motor Replacement (Freestanding Stoves)
PP-69-1	Blower Motor Replacement – Right Hand (Bay Flame Insert)
PP-69	Blower Motor Replacement – Left Hand (Bay Flame Insert)
PP-33	Brass Hinge Pin
PP-880	Brass Shroud Trim Kit (Bay Flame Insert)
PP-883	Oversized Brass Shroud Trim Kit (Bay Flame Insert)
PP-988	Power Cord (Old Style Power Cord, hardwired, is PP-04)
PP-1187	Owners Manual
CF-2200	SD-3 Cast Door Assembly
CF-2210	SD-3 Gold Door Assembly