

Auger Motor Bracket Kit

Part #MF3636

new upgrade bracket for Models 3500P, 3500L, 3502, 7500
(must have a 1 1/2" auger weldment)

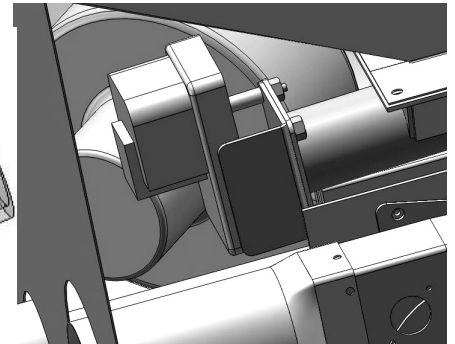
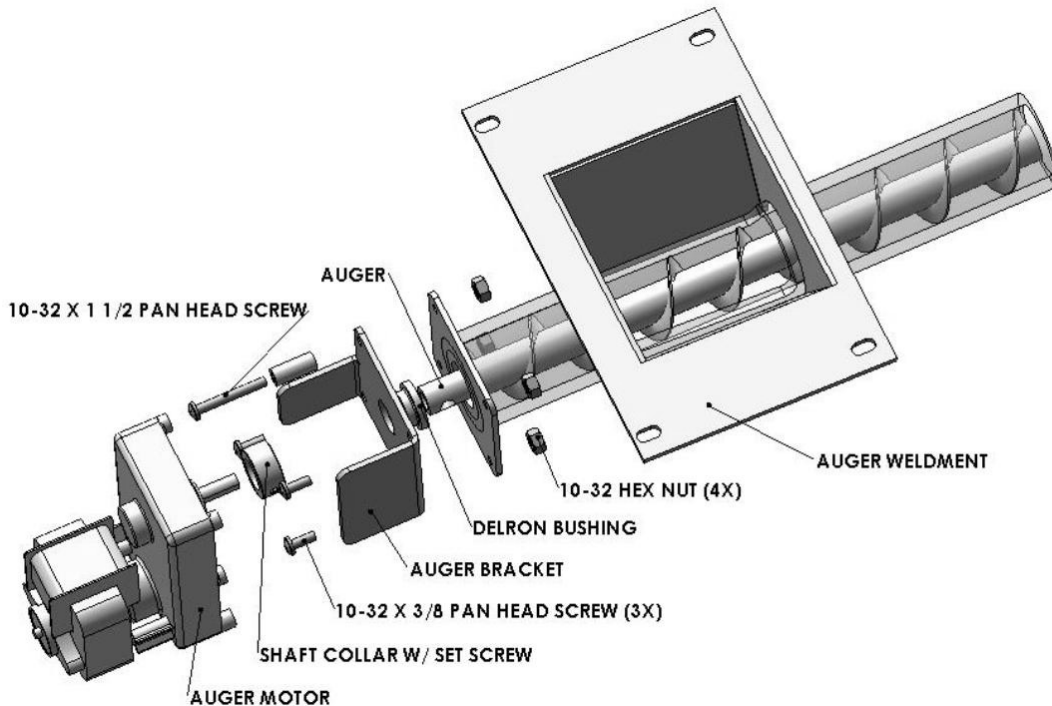

Looking in from LH side

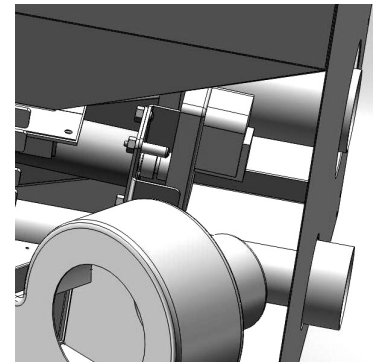

Looking in from RH side

- Turn off power on control panel and unplug from the power supply.
- Open right side panel.
- Loosen allen screw on auger shaft collar w/ set screw.
- Pull off auger motor.
- Remove and discard four 3" long bolts and 5/16" hex nut.
- Remove and discard 3" x 3" plate, make sure the white delron bushing stays on auger shaft.
- Put on new bracket using the (3) 10-32 x 3/8" pan head screws, (1) 10-32 x 1 1/4" pan head screw, 3/4" spacer and the (4) 10-32 hex nuts putting the (1) 10-32 x 1 1/4" with spacers in corner as shown.
- Slide the shaft collar back on auger shaft, aligning the set screw to hole on the auger shaft.
- Slide on the auger motor by aligning the flat shaft on the auger to the allen screw on shaft collar and then tighten the set screw on the collar.
- Reconnect auger motor electrical leads and make sure wires are secured properly in the right panel.
- Close side panel.
- Restart unit.